

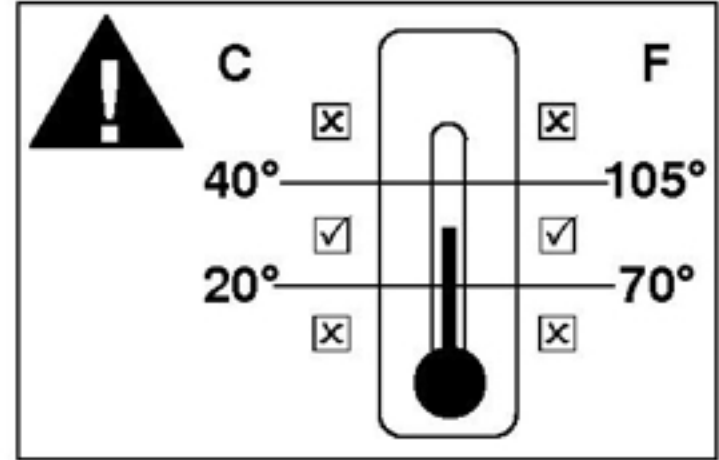

MADE IN ITALY

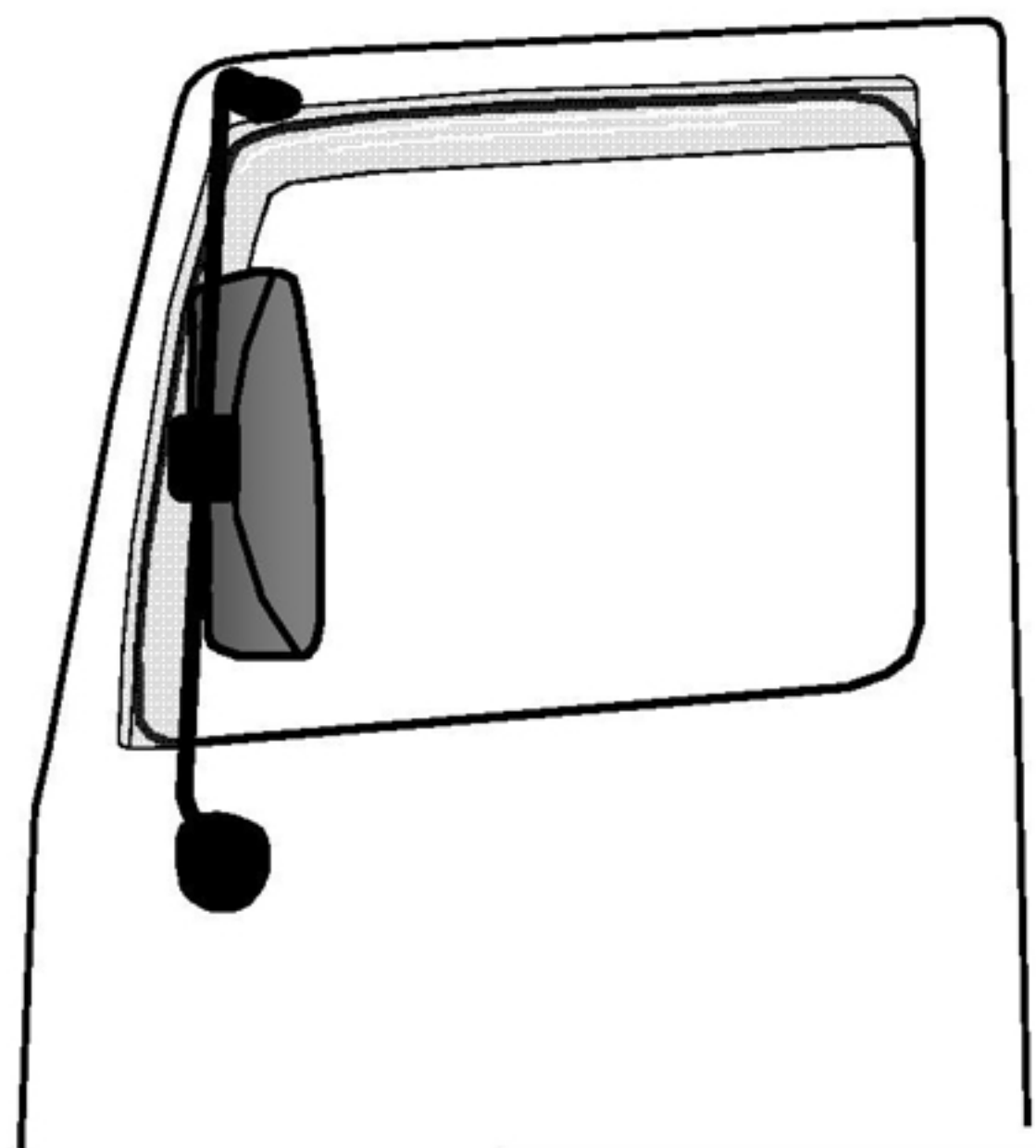

- 1.**
- GB** CHECK THE TEMPERATURE
 - F** CONTROLER LA TEMPERATURE
 - D** LUFTTEMPERATUR PRUEFEN
 - I** VERIFICARE LA TEMPERATURA

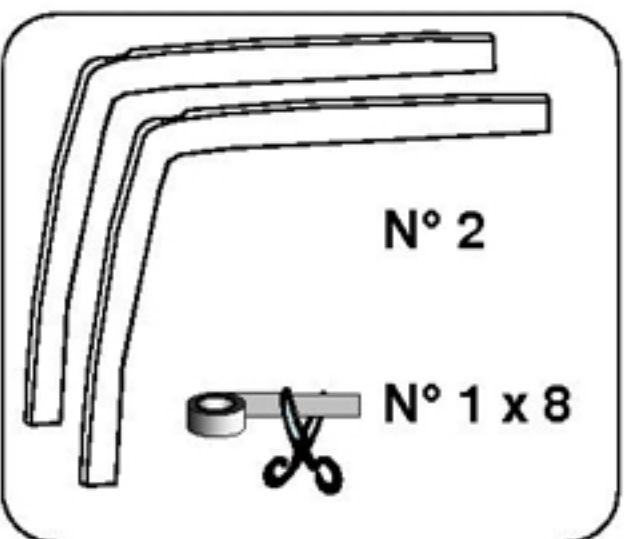
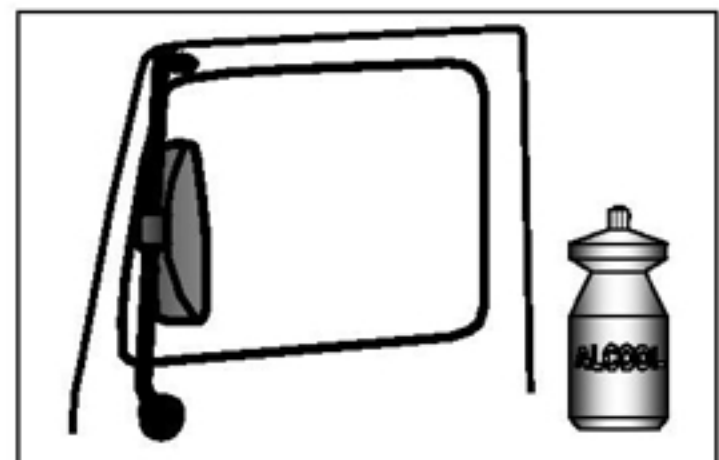

- 2.**
- GB** CLEAN THE SURFACE OF THE DOORS
 - F** NETTOYER LES PORTIERES
 - D** RAHMEN SAEUBERN
 - I** PULIRE LE PORTIERE

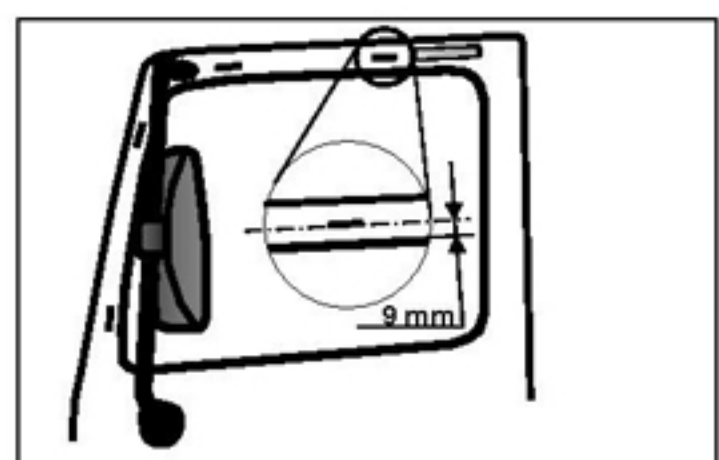

- 3.**
- GB** PLACE THE TEMPLATE ON THE DOORS
 - F** POSITIONNER LES GABARITS
 - D** KLEBER AN DEN PUNKTEN AUFBRINGEN
 - I** POSIZIONARE I RIFERIMENTI D'INCOLLAGGIO

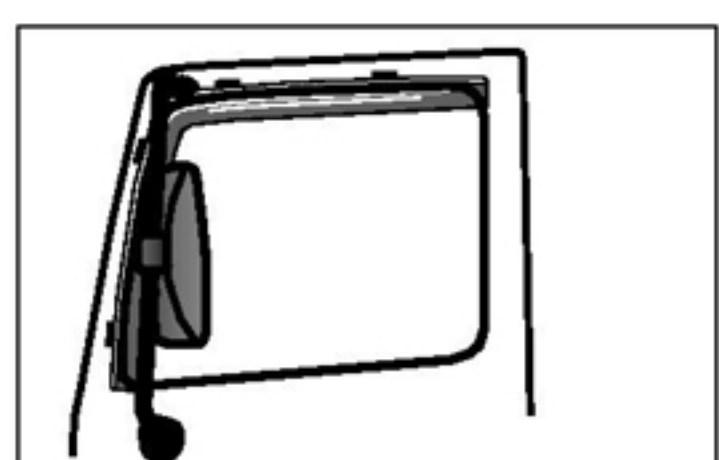

- 4.**
- GB** CHECK THE ALIGNMENT OF THE WIND DEFLECTOR
 - F** CONTROLER L'ALIGNEMENT DU DEFLECTEUR
 - D** SITZ PRUEFEN
 - I** VERIFICARE L'ALLINEAMENTO DEL DEFLETTORE

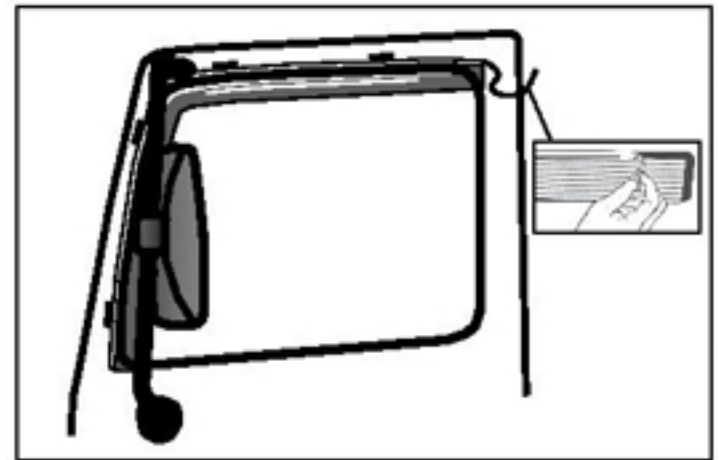

- 5.**
- GB** REMOVE BACKING TAPE AND FASTEN THE WIND DEFLECTOR
 - F** ADHESIVER LES DEFLECTEUR
 - D** FOLIE ENTFERNEN WINDABWEISER ANDRUECKEN
 - I** INCOLLARE I DEFLETTORI D'ARIA

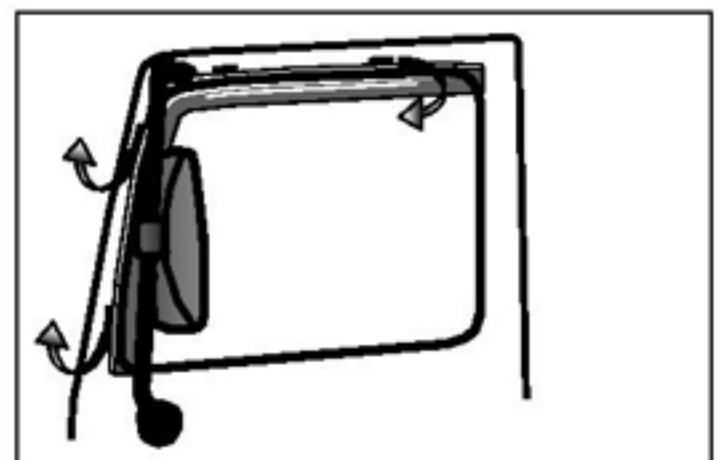

- 6.**
- GB** REMOVE THE TEMPLATE
 - F** DETACHER LES GABARIT
 - D** PUNKTE ENTFERNEN
 - I** TOGLIERE I RIFERIMENTI

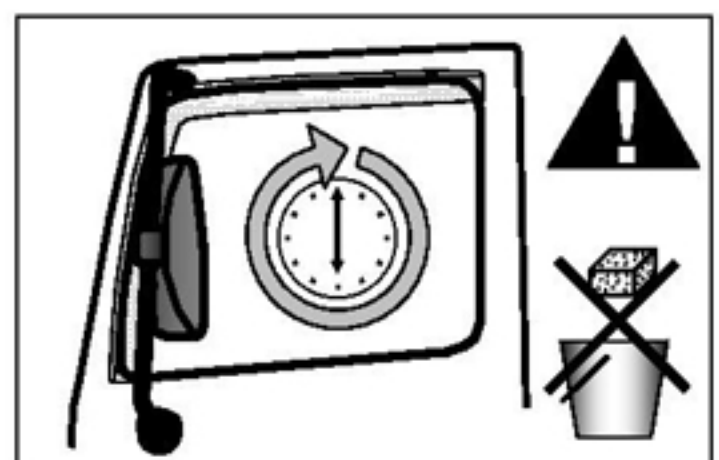

- 7.**
- GB** DO NOT WASH THE TRUCK FOR 24 HOURS
 - F** NE LAVER PAS LA CAMION AVANT 24 HEURS
 - D** 24 STUNDEN NICHT WASCHEN
 - I** NON LAVARE PER 24 ORE L'AUTOVEICOLO

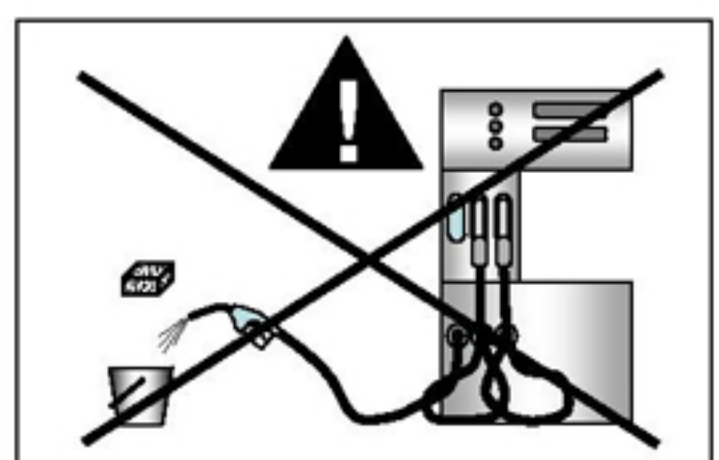

- 8.**
- GB** DO NOT WASH WITH GASOLINE OR DIESEL
 - F** NE LAVER PAS AVEC ESSENCE OU DIESEL
 - D** MIT BENZIN ODER GAZOEL NICHT REINGEN
 - I** NON PULIRE CON BENZINA O GASOLIO