

GENERAL CATALOGUE

CATALOGO GENERALE



FARAD[®]
made in italy

12

**WHEEL LOCKS
AND STANDARD
WHEEL FASTENERS**

BULLONI ANTIFURTO
E BULLONERIA
STANDARD PER RUOTE

50

ROOF BARS
BARRE PORTATUTTO

60

ROOF BOXES
BAULI PORTATUTTO

92

BIKE RACKS
PORTABICI



**BI-COLOR
WHEEL COVERS**

COPRICERCHI BICOLORE

102

PREASSEMBLED BI-COLOR

COPRICERCHI BICOLORE PREASSEMBLATI

104

**UNIVERSAL
WHEEL TRIMS**

COPRICERCHI
UNIVERSALI

114

**WIND
DEFLECTORS**

DEFLETTORI D'ARIA

122



GENERAL PRESENTATION

Farad was founded in 1974 in the field of mould construction for the automotive sector. Thanks to sustained efforts over the years today our company stands, not only as an established partner of most car makers, but also as a leader in the after-market development and marketing of various products which can boast and guarantee 100% made in Italy.

Here's a rundown of our main products:

- Roof boxes
- Roof bars
- Air deflectors
- Universal wheel trims
- Bi-color wheel trims
- Wheel locks
- Bolts and nuts for wheels

La Farad nasce nel 1974 nel campo della costruzione di stampi per il settore automotive. Grazie ad un impegno costante nel corso degli anni, oggi la nostra azienda si afferma, oltre che come partner consolidato della maggior parte dei costruttori d'auto, anche come leader nella realizzazione e commercializzazione nel settore after-market di diversi prodotti che possono vantare e garantire il 100% made in Italy.

Ecco una carrellata dei nostri prodotti principali:

- Bauli portatutto
- Barre portatutto
- Deflettori d'aria
- Copricerchi universali
- Copricerchi bicolore
- Antifurti per ruote
- Bulloni e dadi per ruote

To meet the continually increasing demand, we have, over time, implemented a continuous development program in our human resources, in our facilities and in our infrastructure.

This led to a current workforce of over 300 employees working in the design and co-design, in the production and marketing of products for both OEM and after-market customers using the latest generation of highly technological plants and machineries. We combine elevated productivity with excellent quality, maintaining an absolute respect for the environment.

An example is the water-based coating system, solvent-free and highly eco-friendly.

Our headquarters and two factories form the core of the entire production system which extends over an area of 120,000 m², of which 60,000 m² is covered. Innovation and research, through continuous product and production cycle improvements, have always been the guidelines of our group, which, meeting with increasing customer satisfaction, allow us a continuous growth in the automotive market.

Per far fronte alla continua e crescente domanda, abbiamo attuato nel tempo un incessante sviluppo delle risorse umane, di mezzi e infrastrutture. Questo ci consente di disporre attualmente di un organico di oltre 300 dipendenti impiegati nel design e co-design, nella produzione e commercializzazione dei prodotti, sia per i clienti OEM che per l'after-market. Utilizzando macchinari ed impianti ad alto contenuto tecnologico, di ultima generazione, uniamo all'elevata produttività, un'eccellente qualità nell'assoluto rispetto dell'ambiente. Un esempio è l'impianto di verniciatura all'acqua, senza solventi ed altamente ecologico. Una sede e due stabilimenti costituiscono infine la struttura portante dell'intero sistema produttivo che si estende su un'area di 120.000 m², di cui 60.000 m² coperti. L'innovazione e la ricerca, attraverso il miglioramento continuo dei prodotti e del ciclo produttivo, sono da sempre le linee guida del nostro gruppo che, incontrandosi con la crescente soddisfazione del cliente, ci consente un ininterrotto e progressivo sviluppo nel mercato automotive.



The range is designed in its entirety by our research center, which operates with computerized systems and the latest generation machineries. The production plants, equipped with the best technology adapted for the product, together with the experience and the constantly updated range, guarantee the customer high quality and easy to assemble products. Our extremely wide range of products, developed over the years, positions us as market leader both nationally and internationally, recognized for our quality and originality. Specialized staff carry out the entire design, development and manufacture of moulds for the production of our products.

La gamma è interamente studiata dal nostro centro studi, che opera con sistemi computerizzati e macchinari di ultima generazione. Gli impianti di produzione dotati delle migliori tecnologie adattati ad ogni tipo di prodotto, uniti all'esperienza ed al costante aggiornamento della gamma, garantiscono al cliente prodotti di alta qualità e di facile montaggio. La vastissima gamma sviluppata negli anni ci posiziona sul mercato nazionale ed internazionale come leader riconosciuti ed apprezzati per la nostra qualità ed originalità. Personale specializzato si occupa interamente del design, dello sviluppo e della costruzione degli stampi per la produzione dei nostri prodotti.

OUR MISSION

Responding to market needs and customer requirements, our mission is to create extremely safe, easy to install products, which integrate as much as possible with the specific style of the cars. We also offer a fast and efficient customer service both in Italy and worldwide.

Da sempre attenti alle esigenze del mercato ed alle richieste del cliente, la nostra missione mira a creare prodotti estremamente sicuri, facili da installare e che si integrino il più possibile allo stile specifico delle vetture. Siamo inoltre in grado di offrire un servizio clienti rapido ed efficiente in Italia e nel mondo.



QUALITY

Our company has implemented quality systems throughout all phases from design to the production cycle. In order to ensure the best quality of the product we obtained the following certifications:

- ISO 9001
- ISO 14001
- IATF 16949

In addition, each product category has been subjected to specific tests in order to obtain the approvals required by different markets.

La nostra azienda ha implementato i sistemi di qualità lungo tutte le fasi dalla progettazione al ciclo produttivo. Al fine di garantire la migliore qualità del prodotto abbiamo ottenuto le seguenti certificazioni:

- ISO 9001
- ISO 14001
- IATF 16949

Inoltre ogni categoria di prodotto è stata sottoposta a prove specifiche atte ad ottenere le omologazioni richieste dai diversi mercati di riferimento.



CUSTOMER SERVICE

Thanks to our quick customer support service, our customers can easily get technical information and receive spare parts for any FARAD product quickly and efficiently, both in Italy and worldwide.

Grazie ad un servizio di assistenza clienti veloce e collaudato, per i nostri clienti è estremamente semplice ottenere informazioni tecniche o ricevere, in tempi brevi, ricambi per qualsiasi prodotto della gamma di prodotti FARAD, sia in Italia che nel mondo.

SOCIAL NETWORK

Follow us on Facebook (www.facebook.com/faradworld) and Instagram ([faradworld](https://www.instagram.com/faradworld)) where you will find all the activities and news on our Farad products. Enjoy watching our YouTube videos (www.youtube.com/faradworld) not only related to mounting the different products, but much more.

Seguici su Facebook (www.facebook.com/faradworld) e Instagram ([faradworld](https://www.instagram.com/faradworld)) dove potrai trovare tutte le attività e novità dei nostri prodotti Farad e divertirti a guardare i video Youtube (www.youtube.com/faradworld) dove potrai trovare tutti i video non solo relativi al montaggio dei diversi prodotti, ma molto altro ancora.

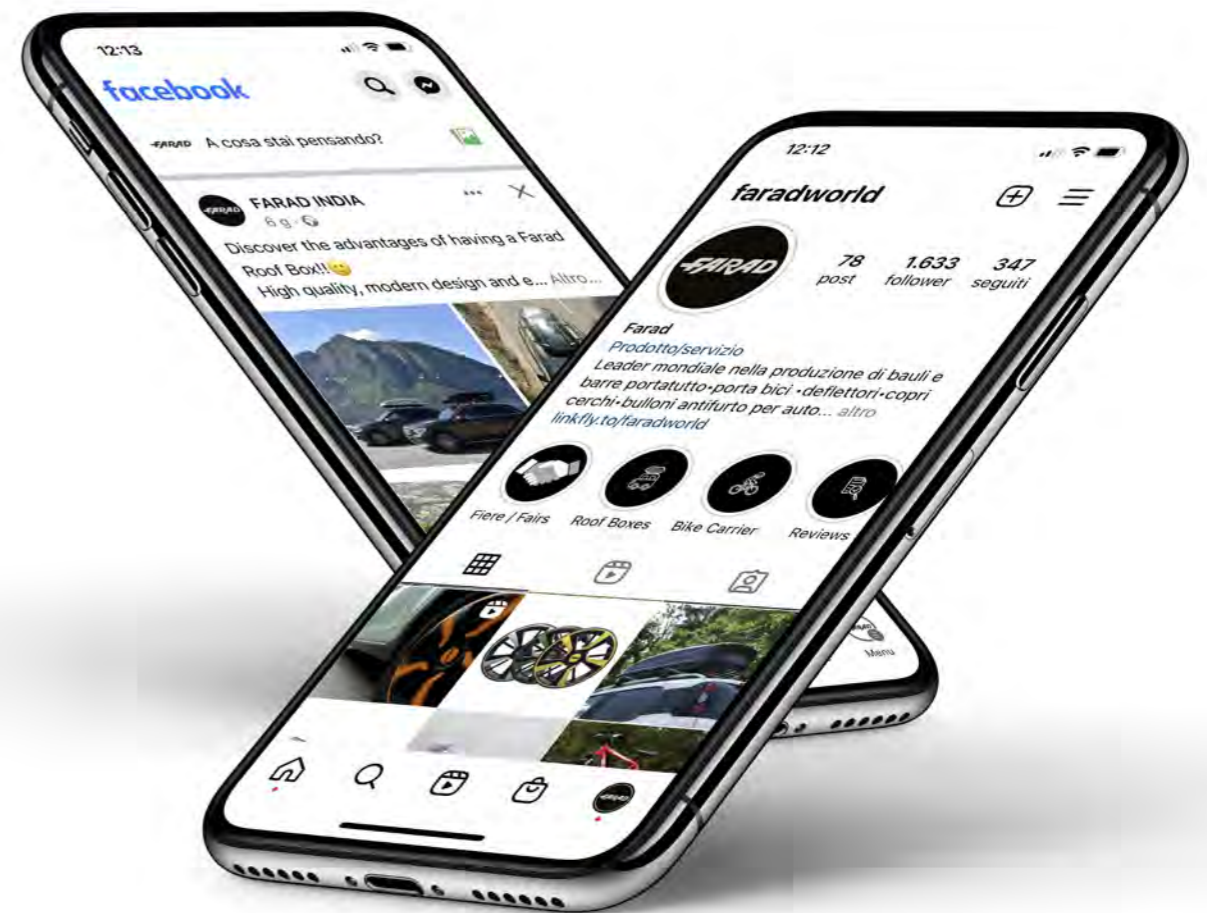

WHEEL LOCKS AND STANDARD WHEEL FASTENERS

BULLONI ANTIFURTO E
BULLONERIA STANDARD PER RUOTE

**FARAD LAUNCHED THE FIRST WHEEL LOCK IN 1978;
THANKS TO AN ONGOING RESEARCH AND PRODUCT'S
DEVELOPMENT, FARAD COMPANY IS THE WORLDWIDE
MARKET LEADER IN THE PRODUCTION OF WHEEL LOCK
SCREWS AND NUTS FOR CARS, VANS AND TRUCKS.
BEING THE OFFICIAL SUPPLIER OF THE MOST IMPORTANT
CAR MAKERS, FARAD HAS OBTAINED THE MOST DEMANDING
QUALITY CERTIFICATIONS IN THE AUTOMOTIVE SECTOR.
FARAD'S MAIN GOAL IS TO OFFER A TECHNOLOGICALLY
ADVANCED PRODUCT WITH HIGH QUALITY STANDARDS THAT
ENSURE A LIFETIME GUARANTEE ON MOST OF OUR PRODUCTS.**

IL PRIMO BULLONE ANTIFURTO DEL GRUPPO FARAD VENNE PRESENTATO NEL 1978;
GRAZIE AD UNA CONTINUA RICERCA E SVILUPPO DEL PRODOTTO,
FARAD OGGI SI CONFERMA COME LEADER MONDIALE NELLA PRODUZIONE
DI BULLONI E DADI ANTIFURTO PER RUOTE DI AUTO,
FURGONI E CAMION. COME FORNITORE UFFICIALE CONSOLIDATO
DELLE MAGGIORI CASE AUTOMOBILISTICHE HA OTTENUTO
LE PIÙ ESIGENTI CERTIFICAZIONI DI QUALITÀ NEL SETTORE DELL'AUTO.
L'OBIETTIVO COMMERCIALE DI FARAD È QUINDI DI OFFRIRE AL MERCATO
UN PRODOTTO TECNOLOGICAMENTE ALL'AVANGUARDIA,
CHE PERMETTA DI PROPORRE UNA QUALITÀ TALE DA POTER GARANTIRE
A VITA LA MAGGIOR PARTE DEI PRODOTTI.



FARAD®

made in Italy

FACTORY
ISO 9001
CERTIFIED

FACTORY
ISO 14001
CERTIFIED

FACTORY
IATF 16949
CERTIFIED

STANDARD BOLTS & NUTS

STANDARD BOLTS | NUTS

Farad manufactures standard wheel bolts (10.9 class steel) and wheel nuts (10 class steel) which can be used as spare parts or for fixing wheels (even if spacers are used). The standard nuts and bolts are cold forged and are available with the silver zinc nickel coating + sealer or with special coatings on demand. We can supply drawings and develop parts to match your exact requirements.

- Produced with the OEM technology, process and controls
- Thread made after heat treatment
- Sealing treatment guarantees better screwing and unscrewing
- Available for all vehicles
- Black coat resistant to acid wheels cleaner
- Bolt's body class resistance 10.9 and nut's body class resistance 10

BULLONI | DADI PER RUOTE

Per completare la nostra offerta ai clienti, disponiamo di una serie di bulloni classe 10.9 e di dadi classe 10 che possono essere utilizzati sia come ricambi, sia per fissare ruote non originali, anche con distanziali. Interamente prodotti con tecnologia stampaggio a freddo, questi prodotti sono disponibili zincati bianchi con sigillante o, se richiesto dal cliente, anche con altri rivestimenti. Su richiesta, si eseguono tipi speciali a disegno.

- Prodotti con tecnologia, processo e controlli OEM
- Filetto eseguito dopo bonifica
- Utilizzo di sigillatura per una migliore garanzia di avvitamento e svitamento
- Disponibili per tutti i tipi di vettura
- Rivestimento nero resistente anche resistente ai detergenti a base acida per lavaggio ruote
- Bulloni classe resistenza 10.9 & dadi classe di resistenza 10



STANDARD BOLTS & NUTS

BOLT 60°
BULLONE 60°

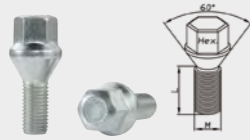

REF.	HEX.	M	L
CC1/S	17	M14x1,5	25
C3B64/S	17	M14x1,5	27
C2C/S	17	M14x1,5	28
C2/S	17	M14x1,5	30
C2L/S	17	M14x1,5	33
B66/S	17	M14x1,5	35
C4C/S	17	M14x1,5	37
B66L/S	17	M14x1,5	38
C4/S	17	M14x1,5	40
C6C/S	17	M14x1,5	42
C6/S	17	M14x1,5	43
C5/S	17	M14x1,5	45
C7/S	17	M14x1,5	47
C7L/S	17	M14x1,5	48
B67/S	17	M14x1,5	50
C8C/S	17	M14x1,5	53
C8/S	17	M14x1,5	55
C9/S	17	M14x1,5	60
C12/S	17	M14x1,5	64
W3/S	19	M14x1,5	28
BF4/S	21	M14x1,5	40
B99/S	19	M16x1,5	32
B100/S	19	M16x1,5	40
BF5/S	21	M16x1,5	40
NBN/S	17	M14x1,25	26
N1BN1/S	17	M14x1,25	28
NBN9/S	17	M14x1,25	31
N13BN13/S	17	M14x1,25	33
N2BN2/S	17	M14x1,25	35
N12BN12/S	17	M14x1,25	38
N3BN3/S	17	M14x1,25	40
N4BN4/S	17	M14x1,25	43
N10BN10/S	17	M14x1,25	45
N5BN5/S	17	M14x1,25	48
N6BN6/S	17	M14x1,25	50
N7BN7/S	17	M14x1,25	55
N8BN8/S	17	M14x1,25	60
PMN9C/S	17	M15x1,25	25
PM11C/S	17	M15x1,25	28
PM15C/S	17	M15x1,25	30
C9B99/S	17	M15x1,25	32
PM12/S	17	M15x1,25	33
J1/S	17	M12x1,75	25
J2/S	17	M12x1,75	30
J3/S	17	M12x1,75	35
J4/S	17	M12x1,75	40
J5/S	17	M12x1,75	45
J6/S	17	M12x1,75	50
CEC/S	17	M10x1,25	17
A1B2/S	17	M12x1,25	22
K1/S	17	M12x1,25	24
KB3/S	17	M12x1,25	26
SH6BV10/S	17	M12x1,25	28
E4BV5/S	17	M12x1,25	30
E5/S	17	M12x1,25	33
E3BV6/S	17	M12x1,25	35
SH9/S	17	M12x1,25	38
SH3BV7/S	17	M12x1,25	40
SH10/S	17	M12x1,25	42
SH4BV8/S	17	M12x1,25	45
SH5BV9/S	17	M12x1,25	50
SH7/S	17	M12x1,25	55
SH8/S	17	M12x1,25	60
GB02/S	19	M12x1,25	22
AB03/S	19	M12x1,25	25
SH11/S	19	M12x1,25	28
E1B05/S	19	M12x1,25	31
EB06/S	19	M12x1,25	35
SHB07/S	19	M12x1,25	40
SH1B08/S	19	M12x1,25	45
SH2B09/S	19	M12x1,25	50
IB211/S	17	M12x1,5	20
IB112/S	17	M12x1,5	23
IB13/S	17	M12x1,5	25
SA8/S	17	M12x1,5	26
I4/S	17	M12x1,5	28
I4B/S	17	M12x1,5	29
IB14/S	17	M12x1,5	30
I6/S	17	M12x1,5	33
SA1B16/S	17	M12x1,5	35
I7/S	17	M12x1,5	38
SAB17/S	17	M12x1,5	40
SA6/S	17	M12x1,5	43
SA2B18/S	17	M12x1,5	45
SA7B/S	17	M12x1,5	47
SA7/S	17	M12x1,5	48
SA3B20/S	17	M12x1,5	50
SA4/S	17	M12x1,5	55
SA5/S	17	M12x1,5	60
PB23/S	19	M12x1,5	25
P2B24/S	19	M12x1,5	30
SFB27/S	19	M12x1,5	40
SF3/S	19	M12x1,5	45
SF2B29/S	19	M12x1,5	50

RADIUS BOLT
BULLONE RAGGIATO

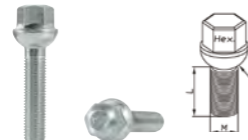

REF.	HEX.	M	L	R
LG13/S	17	M14x1,5	27	12
LG11/S	17	M14x1,5	35	12
LG12/S	17	M14x1,5	36,5	12
LG/S	17	M14x1,5	38	12
LG1/S	17	M14x1,5	40	12
LG6/S	17	M14x1,5	43	12
LG2/S	17	M14x1,5	45	12
LG9/S	17	M14x1,5	48	12
LG3/S	17	M14x1,5	50	12
LG4/S	17	M14x1,5	52	12
LG5/S	17	M14x1,5	56	12
LG7/S	17	M14x1,5	60	12
LG10/S	17	M14x1,5	63	12
SB53/S	17	M14x1,5	24	13
SB95/S	17	M14x1,5	26	13
ZAB54/S	17	M14x1,5	28	13
SB55/S	17	M14x1,5	31	13
SB59/S	17	M14x1,5	33	13
SB56/S	17	M14x1,5	35	13
Z8B50/S	17	M14x1,5	37	13
SB60/S	17	M14x1,5	38	13
Z3B57/S	17	M14x1,5	40	13
Z9B51/S	17	M14x1,5	43	13
SB93/S	17	M14x1,5	45	13
SB94/S	17	M14x1,5	47	13
B88/S	17	M14x1,5	50	13
AL/S	19	M14x1,5	19	13
AL1/S	19	M14x1,5	25	13
AL3/S	19	M14x1,5	34	13
SZAMC/S	17	M14x1,5	27	14
SZAM/S	17	M14x1,5	28	14
SZM/S	17	M14x1,5	31	14
SZ1MC/S	17	M14x1,5	33	14
SZ1M/S	17	M14x1,5	35	14
SZ2M/S	17	M14x1,5	37	14
SZ3M/S	17	M14x1,5	40	14
SZ13M/S	17	M14x1,5	42	14
SZ4M/S	17	M14x1,5	43	14
SZ5M/S	17	M14x1,5	45	14
SZ6M/S	17	M14x1,5	47	14
SZ7MC/S	17	M14x1,5	48	14
SZ7M/S	17	M14x1,5	50	14
SZ8M/S	17	M14x1,5	55	14
SZ11M/S	17	M14x1,5	57	14
SZ9M/S	17	M14x1,5	60	14
SZ10MC/S	17	M14x1,5	63	14
SZ10M/S	17	M14x1,5	65	14
SZ12M/S	17	M14x1,5	68	14
AL3B96/S	19	M14x1,5	34	14
AL4B97/S	19	M14x1,5	47	14
SZ1/S	17	M14x1,25	33	14
SZ2/S	17	M14x1,25	40	14
SZ3/S	17	M14x1,25	43	14
SZ4/S	17	M14x1,25	48	14
SZ5/S	17	M14x1,25	50	14
SZ6/S	17	M14x1,25	51	14
SZ7/S	17	M14x1,25	53	14
ZAB02/S	17	M15x1,25	28	14
ZAB01/S	17	M15x1,25	32	14
ZAB99/S	17	M15x1,25	44	14
ZK1/S	17	M14x1,25	31	13
ZK2/S	17	M14x1,25	42	13
ZK3/S	17	M14x1,25	46	13
ZK4/S	17	M14x1,25	50	13
SZ99M/S	17	M15x1,25	32	13
LB41/S	17	M12x1,5	20	12
L2B42/S	17	M12x1,5	24	12
L1B43/S	17	M12x1,5	25	12
MB44/S	17	M12x1,5	28	12
SG1B46/S	17	M12x1,5	35	12
LB47/S	17	M12x1,5	40	12
HB475/S	17	M12x1,5	43	12
SG2B48/S	17	M12x1,5	45	12
HB485/S	17	M12x1,5	47	12
B49/S	17	M12x1,5	50	12
HB50/S	17	M12x1,5	52	12
HB51/S	17	M12x1,5	55	12
HB52/S	17	M12x1,5	60	12
HB53/S	17	M12x1,5	65	12
SB42/S	17	M12x1,5	23	13
SB41/S	17	M12x1,5	24	13
SB43/S	17	M12x1,5	26	13
SB44/S	17	M12x1,5	28	13
SB45/S	17	M12x1,5	30	13
SB46/S	17	M12x1,5	35	13
SB47/S	17	M12x1,5	40	13
SB48/S	17	M12x1,5	45	13
SB49/S	17	M12x1,5	48	13
SB50/S	17	M12x1,5	50	13
SB51/S	17	M12x1,5	55	13
SB52/S	17	M12x1,5	60	13
B25/S	19	M12x1,5	32	13
Z26/S	17	M12x1,5	26	14
Z21/S	17	M12x1,5	31	14
Z22/S	17	M12x1,5	38	14
Z23/S	17	M12x1,5	41	14
Z24/S	17	M12x1,5	46	14
Z25/S	17	M12x1,5	51	14

BOLT WITH SPHERIC WASHER
BULLONE CON RONDELLA SFERICA

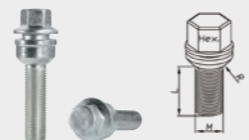

REF.	HEX.	M	L	R
WP20/S	17	M14x1,5	29	13
WP21/S	17	M14x1,5	32	13
WP22/S	17	M14x1,5	36	13
WP23/S	17	M14x1,5	39	13
WP24/S	17	M14x1,5	42	13
WP26/S	17	M14x1,5	45	13
WP25/S	17	M14x1,5	48	13
BPP12/S	17	M14x1,5	30	14
BPP6/S	17	M14x1,5	30	14
BPP5/S	17	M14x1,5	32	14
BPP4/S	17	M14x1,5	35	14
BPP8/S	17	M14x1,5	38	14
BPP9/S	17	M14x1,5	40	14
BPP1/S	17	M14x1,5	42	14
BPP2/S	17	M14x1,5	45	14
BPP7/S	17	M14x1,5	48	14
BPP3/S	17	M14x1,5	50	14
BPP11/S	17	M14x1,5	55	14
BPP40/S	17	M14x1,5	60	14
BPP28/S	19	M14x1,5	26	14
BPP15/S	19	M14x1,5	29	14
BPP18/S	19	M14x1,5	34	14
BPP14/S	19	M14x1,5	36	14
BPP21/S	19	M14x1,5	39	14
BPP20/S	19	M14x1,5	42	14
BPP31/S	19	M14x1,5	43	14
BPP23/S	19	M14x1,5	45	14
BPP29/S	19	M14x1,5	46	14
BPP22/S	19	M14x1,5	48	14
BPP16/S	19	M14x1,5	51	14
BPP17/S	19	M14x1,5	54	14
BPP30/S	19	M14x1,5	56	14
BPP19/S	19	M14x1,5	59	14
BPP28VW/S	19	M14x1,5	26	14
BPP15VW/S	19	M14x1,5	29	14
BPP18VW/S	19	M14x1,5	34	14
BPP14VW/S	19	M14x1,5	36	14
BPP21VW/S	19	M14x1,5	39	14
BPP20VW/S	19	M14x1,5	42	14
BPP31VW/S	19	M14x1,5	43	14
BPP23VW/S	19	M14x1,5	45	14
BPP29VW/S	19	M14x1,5	46	14
BPP22VW/S	19	M14x1,5	48	14
BPP16VW/S	19	M14x1,5	51	14
BPP17VW/S	19	M14x1,5	54	14
BPP30VW/S	19	M14x1,5	56	14
BPP19VW/S	19	M14x1,5	59	14
PM1/S	17	M12x1,5	25	
BR23/S	17	M12x1,5	29	
BR24/S	17	M12x1,5	31	
BR25/S	17	M12x1,5	34	
BR26/S	17	M12x1,5	36	
BR27/S	17	M12x1,5	39	
BR21/S	17	M12x1,5	41	
BR22/S	17	M12x1,5	44	
BR20/S	17	M12x1,5	46	
BR5/S	19	M12x1,5	25	
BR6/S	19	M14x1,5	27	
BPH1/S	19	M14x1,5	33	
BPH2/S	19	M14x1,5	37	
BPH6/S	19	M14x1,5	40	
BPH3/S	19	M14x1,5	43	
BPH4/S	19	M14x1,5	49	
BPH5/S	19	M14x1,5	53	
BF2/S	24	M14x1,5	32	
VV11/S	19	M14x1,5	30,5	
VV12/S	19	M14x1,5	35,5	
VV13/S	19	M14x1,5	40,5	
VV14/S	19	M14x1,5	42,5	
VV15/S	19	M14x1,5	45,5	
VV16/S	19	M14x1,5	48,5	
VV17/S	19	M14x1,5	50,5	
BF3/S	24	M16x1,5	35	
BR10/S	19	M12x1,25	28	
BR9/S	19	M12x1,25	36	
NWR1/S	17	M14x1,25	25	
NWR2/S	17	M14x1,25	28	
NWR3/S	17	M14x1,25	31	
NWR4/S	17	M14x1,25	33	
NWR5/S	17</			

ORIGINAL

BOLTS AND NUTS THAT MEET THE OEM SPECIFICATIONS OF THE AUTOMOTIVE PRODUCTS.

BULLONI E DADI CHE RISPONDONO ALLE SPECIFICHE DELLE CASE AUTOMOBILISTICHE.

BOLT 60°
BULLONE 60°
(stainless steel cap)

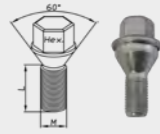

REF.	HEX.	M	L
A1C1/S	17	M12x1,25	22
EHE/S	19	M14x1,5	30

(Black version)



REF.	HEX.	M	L
A3C3/S	17	M12x1,25	22
N3Z/S	17	M14x1,25	27

SPHERICAL BOLT
BULLONE SFERICO

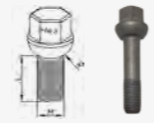

REF.	HEX.	M	L	R
ZJ3/S	19	M14x1,5	52	14

BOLT WITH SPHERIC WASHER
BULLONE CON RONDELLA SFERICA



REF.	HEX.	M	L	R
WP14C/S	17	M14x1,5	27	13
PP12/S	17	M14x1,5	30	14
BPP50/S	19	M14x1,5	36	14

BOLT 60° WITH WASHER
BULLONE CON RONDELLA 60°
(stainless steel cap)

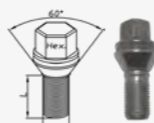

REF.	HEX.	M	L
WP15/S	17	M14x1,5	26

NUT 60°
DADO 60°
(Original plating)

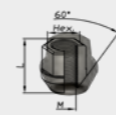

REF.	HEX.	M	L
DE67/S	21	M14x1,5	25

NUT 60°
DADO 60°
(stainless steel cap)

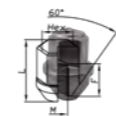

REF.	HEX.	M	F	L
DEF2/S	19	M12x1,5	30	32
DEF3/S	21	M14x1,5	36	38
DEF1/S	21	M14x1,5	40	42

CONICAL NUT WITH FLAT WASHER
DADO CONICO CON RONDELLA PIATTA
(stainless steel cap)

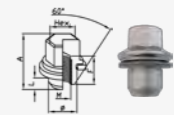

REF.	HEX.	M	φ	L	F	A
AG5/S	22	M14x1,5	22,5	19,5	45	46

(Black version)

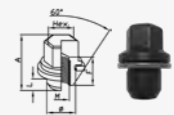

REF.	HEX.	M	φ	L	F	A
AG7L/S	22	M14x1,5	22,5	19,5	25	46

GALAXYLOCK

The Galaxy Lock is the latest addition to Farad's range. This product is Thatcham approved and used by the most important car manufacturers in the world. This endorsement demonstrates the Galaxylock's quality and security. The hardened head withstands attack and the rotating collar cannot be cut. The quality of the design and key engagement means that the Galaxy Lock can withstand up to 400 Nm of torque.

- The combination's design prevents the extraction with tools available on the market
- The key can be easily inserted and taken out of the lock thanks to its automatic centering system
- The wheel lock key's hexagon permits the use of the key given by the car manufacturer
- Strong ROTARY NUT doesn't allow other tools to unscrew it
- Head cut resistant and perforation-proof
- Produced with the OEM technology, process and controls
- The bolt's body class resistance is 10.9 and the nut's body class resistance is 10
- Can withstand up to 400 nm of torque
- Thread made after heat treatment
- Available for all kinds of cars
- Possibility to obtain a new key in case of loss

L'ultimo bullone antifurto prodotto dal gruppo Farad; omologato dalle più importanti case automobilistiche ed approvato dall'istituto inglese Thatcham, è sicuramente l'antifurto più sicuro ed affidabile della gamma, grazie alla sua resistenza alla torsione ad oltre 400Nm, alla rondella antitaglio ed alla testa del bullone-dado imperforabile.

- Il disegno della combinazione impedisce l'estrazione con utensili disponibili sul mercato
- Chiave autocentrante per un facile montaggio e smontaggio
- L'esagono della chiave antifurto permette l'utilizzo della chiave in dotazione con la vettura
- Robusto dado rotante anti taglio che impedisce lo svitamento con utensili
- Testa a prova di perforazione e taglio
- Prodotti con tecnologia, processo e controlli OEM
- Corpo in classe di resistenza 10.9 (bulloni) e classe di resistenza 10 (dadi)
- Resistenza alla torsione oltre a 400nm
- Filettatura eseguita dopo bonifica
- Disponibile per tutti i tipi di vettura
- Possibilità di ottenere la chiave di ricambio in caso di perdita



Thatcham®
Quality Assured

ROTARY HEXAGON
ESAGONO ROTANTE

BOLT 60°
BULLONE 60°



REF.	HEX.	M	L
C1C/M	17	M14X1,5	22
C10/M	17	M14X1,5	25
BD1/M	22	M14x1,5	51
N1/M	17	M14x1,25	28
A1C/M	17	M12X1,25	22
A2C/M	19	M12X1,25	22
E1/M	19	M12X1,25	31
I3/M	17	M12X1,5	24
I5/M	17	M12X1,5	25
I/M	17	M12X1,5	26
I4/M	17	M12X1,5	28
I1/M	17	M12X1,5	30
I7/M	17	M12X1,5	38
SA/M	17	M12X1,5	40
SA2/M	17	M12X1,5	45

FLAT BOLT WITH DIAMETER
BULLONE PIATTO CON DIAMETRO

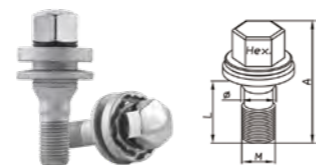

REF.	HEX.	M	ø	L	A
BE8/M	17	M12X1,25	17	36	57

NUT 60° CLOSED
DADO 60° CHIUSO



REF.	HEX.	M	F	L
H/M	19	M12X1,5	25	30
DLF2/M	19	M12X1,5	27	31
H1/M	21	M12X1,5	25	30
HA7/M	19	M12X1,5	32	37
HA13/M	17	M12X1,5	27	32
HA3/M	21	M12X1,5	27	32
HA5/M	21	M12X1,5	32	37
R/M	19	M12X1,25	25	30
DNL/M	21	M12X1,25	25	30
R1/M	21	M12X1,25	25	30
HA10/M	21	M14X2	32	37
HA6/M	19	M14X1,5	32	37
HA8/M	22	M14X1,5	32	37
DCH7/M	21	M14X1,5	36	41
HA4/M	21	M14X1,5	32	37
AD/M	22	M14X1,5	34	39
DCH6/M	22	M14X1,5	36	41
HA9/M	22	M14X1,5	37	42

RADIUS NUT
DADO RAGGIATO

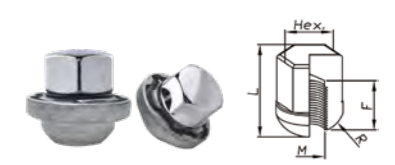

REF.	HEX.	M	F	L	R
AC1C/M	19	M12X1,5	23	26	12
AC2C/M	17	M12X1,5	23	26	12

BOLT 60° WITH WASHER
BULLONE CON RONDELLA 60°

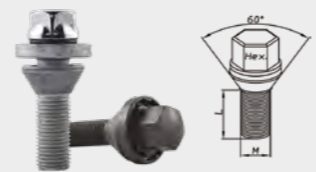

REF.	HEX.	M	L
VV5/M	17	M14X1,5	25
VV3/M	19	M14X1,5	34
KK1/M	17	M12x1,5	24
KK2/M	17	M12x1,5	25
KK3/M	17	M12x1,5	26
KK4/M	17	M12x1,5	28
KK5/M	17	M12x1,5	30
KK6/M	17	M12x1,5	38
KK7/M	17	M12x1,5	40
KK8/M	17	M12x1,5	45

CONICAL NUT WITH FLAT WASHER
DADO CONICO CON RONDELLA PIATTA



REF.	HEX.	M	ø	L	F	A
282AF/M	19	M12X1,5	18,5	8	33	39
382/M	21	M12X1,5	18,5	12	30	35
482/M	21	M12X1,5	18,5	12	38	43
AG5AF/M	22	M14X1,5	22	19	23	45

RADIUS BOLT
BULLONE RAGGIATO

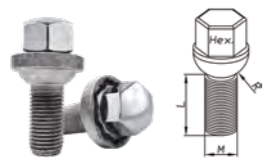

REF.	HEX.	M	L	R
SL10/M	17	M12X1,5	30	12
ZA/M	17	M14X1,5	27	13
Z4/M	17	M14X1,5	45	14
GW/M	19	M14X1,5	31	13
L2/M	17	M12X1,5	24	13
Z9/M	17	M15x1,25	32	14
L9/M	17	M15x1,25	44	14

BOLT WITH SPHERIC WASHER
BULLONE CON RONDELLA SFERICA

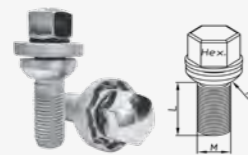

REF.	HEX.	M	L	R
WP14/M	17	M14X1,5	27	13
PP12/M	17	M14X1,5	30	14
VV6/M	17	M14X1,5	33	14
PM1AF/M	17	M15x1,25	44	14

NUT 60° WITH WASHER
DADO 60° CON RONDELLA



REF.	HEX.	M	F	L
T2/M	19	M12X1,5	28	33

Starlock

The StarLock wheel lock is Thatcham approved and used by many of the largest car manufacturers in the world. These endorsements demonstrate the StarLock's quality and security. The hardened head withstands any attack and the rotary ring cannot be cut. The quality of the design and key engagement means that the StarLock can withstand up to 400 Nm of torque.

- The combination's design prevents the extraction with tools available on the market
- The key can be easily inserted and taken out of the lock thanks to its automatic centering system
- The wheel lock key's hexagon permits the use of the key given by the car manufacturer
- Strong rotating ring which doesn't allow other tools to unscrew it
- Head cut resistant and perforation-proof
- Produced with the OEM technology, process and controls
- The bolt's body class resistance is 10.9 and the nut's body class resistance is 10
- Can withstand up to 400 nm of torque
Thread made after heat treatment
- Available for all kinds of cars
- Possibility to obtain a new key in case of loss

Omologato dalle più importanti case automobilistiche ed approvato dall'istituto inglese Thatcham, è sicuramente l'antifurto più sicuro ed affidabile della gamma, grazie alla sua resistenza alla torsione ad oltre 400Nm, alla rondella antitaglio ed alla testa del bullone-dado imperforabile.

- Il disegno della combinazione impedisce l'estrazione con utensili disponibili sul mercato
- Chiave autocentrante per un facile montaggio e smontaggio
- L'esagono della chiave antifurto permette l'utilizzo della chiave in dotazione con la vettura
- Robusto anello rotante anti taglio che impedisce lo svitamento con utensili
- Testa a prova di perforazione e taglio
- Prodotti con tecnologia, processo e controlli OEM
- Corpo in classe di resistenza 10.9 (bulloni) e classe di resistenza 10 (dadi)
- Resistenza alla torsione oltre a 400nm
- Filettatura eseguita dopo bonifica
Disponibile per tutti i tipi di vettura
- Possibilità di ottenere la chiave di ricambio in caso di perdita



Thatcham®
Quality Assured

ROTARY RING
RONDELLA ROTANTE

BOLT 60°
BULLONE 60°

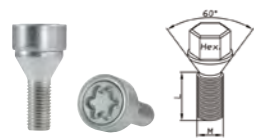

REF	HEX.	M	L
C1C/E	17	M14X1,5	23
C1/E	17	M14X1,5	26
C2C/E	17	M14X1,5	28
C2/E	17	M14X1,5	30
C/E	17	M14X1,5	31
C3C/E	17	M14X1,5	33
C3/E	17	M14X1,5	35
C4C/E	17	M14X1,5	38
C4/E	17	M14X1,5	40
C5C/E	17	M14X1,5	43
C5/E	17	M14X1,5	45
C6C/E	17	M14X1,5	47
C6/E	17	M14X1,5	50
C7/E	17	M14X1,5	55
C8/E	17	M14X1,5	60
C9/E	17	M14X1,5	70
W2/E	19	M14X1,5	26
W3/E	19	M14X1,5	30
W8/E	19	M14X1,5	35
EH1/E	19	M14X1,5	29
BF4/E	21	M14X1,5	29
BD1/E	22	M14X1,5	35
N/E	17	M14X1,25	25
N1/E	17	M14X1,25	28
N9/E	17	M14X1,25	31
N2/E	17	M14X1,25	33
N3/E	17	M14X1,25	35
N12/E	17	M14X1,25	38
N4/E	17	M14X1,25	40
N10/E	17	M14X1,25	43
N5/E	17	M14X1,25	45
N11/E	17	M14X1,25	48
N6/E	17	M14X1,25	50
N7/E	17	M14X1,25	55
N8/E	17	M14X1,25	60
SN/E	19	M14X1,25	25
SN1/E	19	M14X1,25	28
SN9/E	19	M14X1,25	31
SN2/E	19	M14X1,25	33
SN3/E	19	M14X1,25	35
SN12/E	19	M14X1,25	38
SN4/E	19	M14X1,25	40
SN10/E	19	M14X1,25	43
SN5/E	19	M14X1,25	45
SN11/E	19	M14X1,25	48
SN6/E	19	M14X1,25	50
SN7/E	19	M14X1,25	55
SN8/E	19	M14X1,25	60
BR11/E	19	M16X1,5	33
BD3/E	19	M16X1,5	33
BF5/E	21	M16X1,5	30
BD2/E	22	M16X1,5	35
BD24/E	24	M16X1,5	35
BD9/E	17	M15X1,25	28
J1/E	19	M12X1,75	25
J2C/E	19	M12X1,75	30
A1C/E	17	M12X1,25	22
K/E	17	M12X1,25	25
E5/E	17	M12X1,25	28
E4/E	17	M12X1,25	31
E3/E	17	M12X1,25	35
SH3/E	17	M12X1,25	40
SH4/E	17	M12X1,25	45
SH5/E	17	M12X1,25	50
SH6/E	17	M12X1,25	60
A2C/E	19	M12X1,25	22
A/E	19	M12X1,25	25
SH7/E	19	M12X1,25	28
E1/E	19	M12X1,25	31
E	19	M12X1,25	35
SH/E	19	M12X1,25	40
SH1/E	19	M12X1,25	45
SH2/E	19	M12X1,25	50
I2/E	17	M12X1,5	23
I3/E	17	M12X1,5	24
I5/E	17	M12X1,5	25
I/E	17	M12X1,5	26
I4/E	17	M12X1,5	29
I1/E	17	M12X1,5	32
SA1/E	17	M12X1,5	34
I8/E	17	M12X1,5	36
I7/E	17	M12X1,5	38
SA/E	17	M12X1,5	40
SAB/E	17	M12X1,5	43
SA2/E	17	M12X1,5	45
SA3/E	17	M12X1,5	48
SA9/E	17	M12X1,5	50
SA4/E	17	M12X1,5	56
SA5/E	17	M12X1,5	60
SA6/E	17	M12X1,5	70
P1/E	19	M12X1,5	24
P/E	19	M12X1,5	26
SF/E	19	M12X1,5	40

RADIUS BOLT
BULLONE RAGGIATO

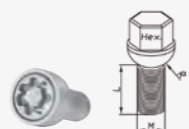

REF	HEX.	M	L	R
Z/E	17	M14X1,5	25	13
ZA/E	17	M14X1,5	27	13
ZAM/E	17	M14X1,5	27	14
Z1/E	17	M14X1,5	29	13
Z7/E	17	M14X1,5	32	13
Z16/E	17	M14X1,5	33	13
Z2/E	17	M14X1,5	35	13
Z10/E	17	M14X1,5	37	13
Z17/E	17	M14X1,5	38	13
Z11/E	17	M14X1,5	40	13
Z3/E	17	M14X1,5	42	13
Z15/E	17	M14X1,5	45	13
Z4/E	17	M14X1,5	45	14
Z12/E	17	M14X1,5	47	13
Z14/E	17	M14X1,5	50	13
Z5/E	17	M14X1,5	52	13
Z8/E	17	M14X1,5	55	13
Z6/E	17	M14X1,5	60	13
Z9/E	17	M14X1,5	70	13
SZAMC/E	17	M14X1,5	26	14
SZAM/E	17	M14X1,5	28	14
SZM/E	17	M14X1,5	31	14
SZ1MC/E	17	M14X1,5	33	14
SZ1M/E	17	M14X1,5	35	14
SZ2M/E	17	M14X1,5	37	14
SZ3M/E	17	M14X1,5	40	14
SZ4M/E	17	M14X1,5	43	14
SZ5M/E	17	M14X1,5	45	14
SZ6M/E	17	M14X1,5	47	14
SZ7MC/E	17	M14X1,5	48	14
SZ7M/E	17	M14X1,5	50	14
ZJ/E	17	M14X1,5	53	14
SZ8M/E	17	M14X1,5	55	14
SZ11M/E	17	M14X1,5	57	14
SZ9M/E	17	M14X1,5	60	14
SZ10MC/E	17	M14X1,5	63	14
SZ10M/E	17	M14X1,5	65	14
SZ12M/E	17	M14X1,5	68	14
AL/E	19	M14X1,5	25	13
AL1/E	19	M14X1,5	27	13
AL3/E	19	M14X1,5	35	13
AL6/E	19	M14X1,5	52	13
LG/E	17	M14X1,5	38	12
LG1/E	17	M14X1,5	41	12
LG8/E	17	M14X1,5	43	12
LG2/E	17	M14X1,5	45	12
LG9/E	17	M14X1,5	48	12
LG3/E	17	M14X1,5	50	12
LG4/E	17	M14X1,5	52	12
LG5/E	17	M14X1,5	56	12
LG7/E	17	M14X1,5	60	12
LG10/E	17	M14X1,5	63	12
Z99/E	17	M15X1,25	32	14
LG99/E	17	M15X1,25	44	14
L/E	17	M12X1,5	21	12
LS/E	17	M12X1,5	25	12
LS1/E	15	M12X1,5	25	12
SG/E	17	M12X1,5	40	12
SL/E	17	M12X1,5	28	12
SL1/E	17	M12X1,5	35	12
SL2/E	17	M12X1,5	40	12
SL3/E	17	M12X1,5	43	12
SL4/E	17	M12X1,5	45	12
SL5/E	17	M12X1,5	47	12
SL6/E	17	M12X1,5	50	12
SL7/E	17	M12X1,5	52	12
SL8/E	17	M12X1,5	55	12
SL9/E	17	M12X1,5	60	12
SL29/E	19	M12X1,5	40	12
L2/E	17	M12X1,5	24	13
L2B/E	17	M12X1,5	26	13
M/E	17	M12X1,5	28	13
M1/E	17	M12X1,5	31	13
SG1/E	17	M12X1,5	35	13
SG2/E	17	M12X1,5	45	13
SG4/E	17	M12X1,5	50	13
SG5/E	17	M12X1,5	56	13
SG6/E	17	M12X1,5	60	13
SG7/E	17	M12X1,5	70	13

BOLT WITH SPHERIC WASHER
BULLONE CON RONDELLA SFERICA



REF	HEX.	M	L	R
PP12/E	17	M14X1,5	30	14
BPP5/E	17	M14X1,5	32	14
BPP4/E	17	M14X1,5	35	14
PP147/E	17	M14X1,5	36	14
BPP8/E	17	M14X1,5	38	14
BPP9/E	17	M14X1,5	40	14
BPP1/E	17	M14X1,5	42	14
BPP2/E	17	M14X1,5	45	14
BPP7/E	17	M14X1,5	48	14
BPP3/E	17	M14X1,5	50	14
BPP11/E	17	M14X1,5	55	14
BPP12/E	17	M14X1,5	60	14
PP28/E	19	M14X1,5	26	14
PP13/E	19	M14X1,5	29	14
PP15/E	19	M14X1,5	34	14
PP11/E	19	M14X1,5	35	14
PP14/E	19	M14X1,5	36	14
PP14RD26/E	19	M14X1,5	36	14
PP21/E	19	M14X1,5	37	14
PP16/E	19	M14X1,5	39	14
PP17/E	19	M14X1,5	43	14
PP22/E	19	M14X1,5	45	14
PP29/E	19	M14X1,5	46	14
PP23/E	19	M14X1,5	48	14
PP18/E	19	M14X1,5	50	14
PP24/E	19	M14X1,5	53	14
PP19/E	19	M14X1,5	54	14
PP30/E	19	M14X1,5	56	14
PP20/E	19	M14X1,5	59	14
WP14/E	17	M14X1,5	28	13
WP20/E	17	M14X1,5	29	13
WP21/E	17	M14X1,5	32	13
WP22/E	17	M14X1,5	36	13
WP15/E	17	M14X1,5	38	13
WP23/E	17	M14X1,5	39	13
WP24/E	17	M14X1,5	42	13
WP16/E	17	M14X1,5	43	13
WP26/E	17	M14X1,5	45	13
WP25/E	17	M14X1,5	48	13
WP17/E	17	M14X1,5	50	13
PM1/E	17	M15X1,25	44	14
PM2/E	17	M15X1,25	47	14
PM3/E	17	M15X1,25	49	14
PM4/E	17	M15X1,25	54	14
PM5/E	17	M15X1,25	57	14
PM6/E	17	M15X1,25	59	14
PM7/E	17	M15X1,25	62	14
PM8/E	17	M15X1,25	64	14

FLAT BOLT WITH DIAMETER
BULLONE PIATTO CON DIAMETRO

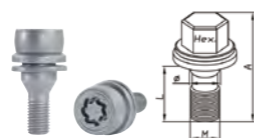

REF	HEX.	M	ø	L	A
BE8/E	17	M12X1,25	17	36	55
CP2/E	17	M12X1,25	17	41	60
CP4/E	17	M12X1,25	17	51	70
CP5/E	17	M12X1,25	17	56	75
CP6/E	17	M12X1,25	17	61	80
BB8/E	19	M12X1,25	17	36	55
BD8/E	21	M12X1,25	17	36	55
BC4/E	17	M12X1,5	18,5	33	53

FLAT BOLT WITH WASHER
BULLONE PIATTO CON RONDELLA

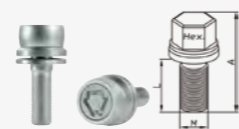

REF	HEX.	M	L	A
ZH1/E	17	M12X1,25	35	55
AH1/E	19	M12X1,25	35	55

BOLT 60° WITH WASHER
BULLONE CON RONDELLA 60°



REF	HEX.	M	L
BR37/E	17	M12X1,5	25
BR7/E	17	M12X1,5	33
BR3/E	19	M12X1,5	25
BR13/E	17	M12X1,25	26
BR47/E	17	M14X1,5	28
BR4/E	19	M14X1,5	28
FK5/E	17	M14X1,5	31
VV1/E	19	M14X1,5	31
BF2/E	24	M14X1,5	32
BF3/E	24	M16X1,5	35
NWR1/E	17	M14X1,25	25
NWR2/E	17	M14X1,25	28
NWR3/E	17	M14X1,25	31
NWR4/E	17	M14X1,25	33
NWR5/E	17	M14X1,25	39
NWR6/E	17	M14X1,25	41
NWR7/E	17	M14X1,25	43
NWR8/E	17	M14X1,25	46
NWR9/E	17	M14X1,25	48
NWR10/E	17	M14X1,25	50
NWR11/E	17	M14X1,25	53

BOLT INNER-AXE VARIATION
BULLONE VARIAZIONE INTERASSE

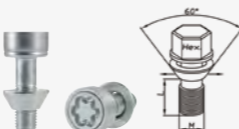

REF	HEX.	M	L
BS/E	17	M12X1,5	28
BS1C/E	17	M12X1,5	33
BS1/E	17	M12X1,5	35
BS2/E	17	M12X1,5	40
BS3/E	17	M12X1,5	44
BP3/E	17	M12X1,25	28
BP1/E	17	M12X1,25	35



The FlowerLock was specially conceived for car manufacturers. It offers excellent security for all alloy and steel wheels thanks to the complex combination patterns and the heavy-duty rotary ring.

- The combination's design prevents the extraction with tools available on the market
- The wheel lock key's hexagon permits also the use of the key given by the car manufacturer
- Strong rotating ring which doesn't allow other tools to unscrew it
- Produced with the OEM technology, process and controls
- Bolt's body class resistance 10.9 and nut's body class resistance 10
- Thread made after heat treatment
- Possibility to obtain a new key in case of loss

Studiato specificatamente per le case automobilistiche, FlowerLock, grazie al suo disegno a forma di fiore ed a una rondella particolarmente robusta, è un antifurto estremamente sicuro per qualsiasi tipo di ruota in lega o acciaio.

- Il disegno della combinazione impedisce la rimozione con utensili in commercio
- L'esagono della chiave antifurto permette l'utilizzo della chiave in dotazione con la vettura
- Robusto anello rotante anti taglio che impedisce lo svitamento con utensili
- Prodotti con tecnologia, processo e controlli OEM
- Corpo in classe di resistenza 10.9 (bulloni) e classe di resistenza 10 (dadi)
- Filettatura eseguita dopo bonifica
- Possibilità di ottenere la chiave di ricambio in caso di perdita



ROTARY RING
RONDELLA ROTANTE

BOLT 60°
BULLONE 60°



REF.	HEX.	M	L
B64/D	17	M14X1,5	26
B65C/D	17	M14X1,5	29
B65/D	17	M14X1,5	31
B66C/D	17	M14X1,5	33
B66/D	17	M14X1,5	35
B68/D	17	M14X1,5	40
B67/D	17	M14X1,5	50
B74/D	19	M14X1,5	26
B75C/D	19	M14X1,5	29
B75/D	19	M14X1,5	31
B76C/D	19	M14X1,5	33
B76/D	19	M14X1,5	35
B78/D	19	M14X1,5	40
B77/D	19	M14X1,5	50
N1/D	17	M14x1,25	28
N2/D	17	M14x1,25	35
N3/D	17	M14x1,25	40
BV2/D	17	M12X1,25	22
BV3/D	17	M12X1,25	26
BV5C/D	17	M12X1,25	28
BV5/D	17	M12X1,25	31
BV6/D	17	M12X1,25	35
BV7/D	17	M12X1,25	40
BV8/D	17	M12X1,25	45
BV9/D	17	M12X1,25	50
B02/D	19	M12X1,25	22
B03/D	19	M12X1,25	26
B05C/D	19	M12X1,25	28
B05/D	19	M12X1,25	31
B06/D	19	M12X1,25	35
B07/D	19	M12X1,25	40
B08/D	19	M12X1,25	45
B09/D	19	M12X1,25	50
B11/D	17	M12X1,5	18
B12/D	17	M12X1,5	21
B13/D	17	M12X1,5	23
B13L/D	17	M12X1,5	25
B14/D	17	M12X1,5	28
B16/D	17	M12X1,5	34
B17/D	17	M12X1,5	38
B18/D	17	M12X1,5	43
B20/D	17	M12X1,5	48
B21/D	19	M12X1,5	18
B22/D	19	M12X1,5	21
B23/D	19	M12X1,5	23
B24/D	19	M12X1,5	28
B26/D	19	M12X1,5	34
B27/D	19	M12X1,5	38
B28/D	19	M12X1,5	43
B30/D	19	M12X1,5	48

RADIUS BOLT
BULLONE RAGGIATO



REF.	HEX.	M	L	R
B53/D	17	M14X1,5	25	13
B54/D	17	M14X1,5	28	13
B55/D	17	M14X1,5	30	13
B56C/D	17	M14X1,5	32	13
B56/D	17	M14X1,5	35	13
B57/D	17	M14X1,5	40	13
B58/D	17	M14X1,5	45	13
B88/D	17	M14X1,5	50	13
B86/D	17	M14X1,5	55	13
B87/D	17	M14X1,5	60	13
B59/D	17	M14X1,5	70	13
B93/D	19	M14X1,5	25	13
B92/D	19	M14X1,5	28	13
B95/D	19	M14X1,5	30	13
B96C/D	19	M14X1,5	32	13
B96/D	19	M14X1,5	35	13
B97/D	19	M14X1,5	40	13
B94/D	19	M14X1,5	45	13
B98/D	19	M14X1,5	52	13
B41/D	17	M12X1,5	20	12
B42/D	17	M12X1,5	23	12
B44/D	17	M12X1,5	28	12
B46/D	17	M12X1,5	35	12
B47/D	17	M12X1,5	40	12
B48/D	17	M12X1,5	45	12

NUT 60° OPEN
DADO 60° APERTO

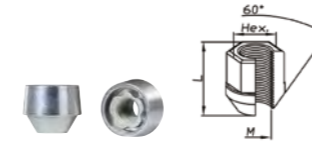

REF.	HEX.	M	L
D6/D	17	M12X1,5	20
D37/D	19	M12X1,5	20
D27/D	21	M12X1,5	20
D47/D	17	M12X1,25	20
D57/D	19	M12X1,25	20
D17/D	21	M12X1,25	20

NUT 60° WITH WASHER
DADO 60° CON RONDELLA

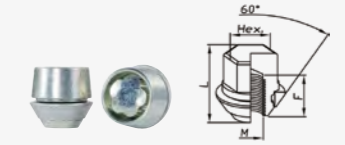

REF.	HEX.	M	F	L
DA1/D	19	M12X1,5	23	26
DA2/D	17	M12X1,5	23	26

FLAT BOLT WITH WASHER
BULLONE PIATTO CON RONDELLA

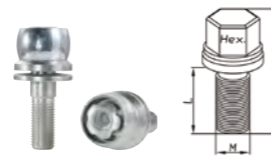

REF.	HEX.	M	L	A
BF6/D	17	M12X1,25	35	59
BE6/D	17	M12X1,25	35	66
BA6/D	19	M12X1,25	35	66
BB6/D	19	M12X1,25	35	59
BX8/D	19	M12X1,25	43	67

NUT 60° CLOSED
DADO 60° CHIUSO

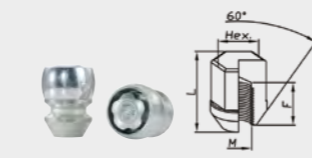

REF.	HEX.	M	F	L
D7/D	17	M12X1,5	25	34
D2/D	19	M12X1,5	25	34
D4/D	21	M12X1,5	25	34
D16/D	17	M12X1,25	25	34
D12/D	19	M12X1,25	25	34
D14/D	21	M12X1,25	25	34
D60/D	19	1/2" UNF	24	34
D81/D	19	7/16" UNF	25	34
D32/D	19	M14X1,5	26	34
D51/D	21	M14X1,5	26	34

RADIUS NUT
DADO RAGGIATO

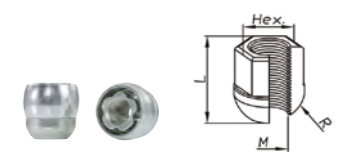

REF.	HEX.	M	L	R
D21/D	17	M12X1,5	26	12
D22/D	19	M12X1,5	26	12
D5/D	21	M12X1,5	26	12

FLAT BOLT WITH DIAMETER
BULLONE PIATTO CON DIAMETRO

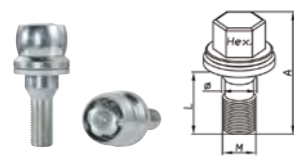

REF.	HEX.	M	φ	L	A
BB8/D	19	M12X1,25	17	36	61
BE8/D	17	M12X1,25	17	36	61
BD8/D	21	M12X1,25	17	36	61
BC4/D	17	M12X1,5	18,5	33	57

BOLT 60° WITH WASHER
BULLONE CON RONDELLA 60°



REF.	HEX.	M	L
BR37/D	17	M12X1,5	25
BR3/D	19	M12X1,5	25
BR47/D	17	M14X1,5	28
BR4/D	19	M14X1,5	28

Stil Bull

Available from over 40 years it fits all original equipment and aftermarket wheels on all cars (European, Asian and American cars etc). The combinations on the head is protected by hexagonal stainless steel caps which make the wheel lock bright and attractive on your wheels.

- High-resistant pins for a secure hold
- The key can be easily inserted and taken out of the lock thanks to its automatic centering system
- The wheel lock key's hexagon permits the use of the key given by the car manufacture
- Strong rotating ring which doesn't allow other tools to unscrew it
- Bolt's body class resistance 10.9 and nut's body class resistance 10
- Available for all cars
- Possibility to obtain a new key in case of loss

È l'antifurto più conosciuto sul mercato da ben oltre 40 anni, è disponibile per tutte le vetture europee, asiatiche ed americane, per le ruote in lega e non originali. Le combinazioni prodotte sulla testa del bullone sono protette da un tappo esagonale in acciaio inox che rende l'aspetto finale dell'antifurto brillante e molto gradevole quando viene montato sulla ruota.

- Perni in acciaio ultraresistenti per una tenuta sicura
- Chiave autocentrante per un facile montaggio e smontaggio
- Esagono della chiave antifurto che permette l'utilizzo della chiave in dotazione con la vettura
- Anello rotante che impedisce lo svitamento con utensili
- Corpo in classe di resistenza 10.9 (bulloni) e con classe di resistenza 10 (dadi)
- Disponibile per tutti i tipi di vettura
- Possibilità di ottenere la chiave di ricambio in caso di perdita



ROTARY RING
RONDELLA ROTANTE

BOLT 60°
BULLONE 60°

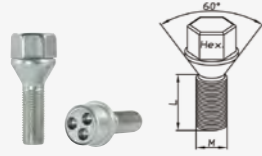

REF.	HEX.	M	L
C1	17	M14X1,5	25
C2	17	M14X1,5	29
C3	17	M14X1,5	35
C4	17	M14X1,5	40
C5	17	M14X1,5	45
791	19	M14X1,5	20
W2	19	M14X1,5	25
W3	19	M14X1,5	29
W8	19	M14X1,5	35
W5	19	M14X1,5	40
N1	17	M14X1,25	28
J1	19	M12X1,75	25
J2	19	M12X1,75	28
A1	17	M12X1,25	22
K	17	M12X1,25	25
E4	17	M12X1,25	31
E3	17	M12X1,25	35
SH3	17	M12X1,25	40
SH4	17	M12X1,25	45
SH5	17	M12X1,25	50
G	19	M12X1,25	22
A	19	M12X1,25	25
SH7	19	M12X1,25	27
E2	19	M12X1,25	29
E1	19	M12X1,25	31
E	19	M12X1,25	35
SH	19	M12X1,25	40
SH1	19	M12X1,25	45
SH2	19	M12X1,25	50
I2	17	M12X1,5	20
I3	17	M12X1,5	23
I	17	M12X1,5	26
I4	17	M12X1,5	28
I1	17	M12X1,5	30
SA1	17	M12X1,5	35
SA	17	M12X1,5	40
SA2	17	M12X1,5	45
SA3	17	M12X1,5	50
387	19	M12X1,5	20
P1	19	M12X1,5	23
P	19	M12X1,5	26
P2	19	M12X1,5	30
P3	19	M12X1,5	35
SF	19	M12X1,5	40
PP1	21	M12X1,5	20
PP2	21	M12X1,5	26

RADIUS BOLT
BULLONE RAGGIATO

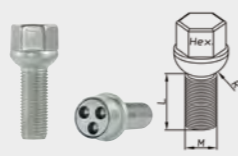

REF.	HEX.	M	L	R
Z	17	M14X1,5	25	13
ZA	17	M14X1,5	27	13
Z2	17	M14X1,5	35	13
Z3	17	M14X1,5	40	13
Z4	17	M14X1,5	45	13
Z5	17	M14X1,5	70	13
691	19	M14X1,5	20	13
AL	19	M14X1,5	25	13
AL1	19	M14X1,5	27	13
AL3	19	M14X1,5	35	13
AL4	19	M14X1,5	40	13
AL5	19	M14X1,5	45	13
AL6	19	M14X1,5	52	13
L	17	M12X1,5	20	12
L2	17	M12X1,5	24	12
M	17	M12X1,5	28	12
SG1	17	M12X1,5	35	12
SG	17	M12X1,5	40	12
SG2	17	M12X1,5	45	12
AHD	19	M12X1,5	28	12
SG3	19	M12X1,5	40	12
ALKO 10	19	M10X1,25	22	12

CONICAL OR RADIUS BOLT WITH LONG HEAD
BULLONE CONICO O RAGGIATO CON TESTA ALLUNGATA

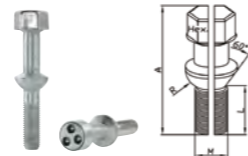

REF.	HEX.	M	L	A	SEDE
SGX	17	M12X1,5	40	92	12
SGY	17	M12X1,5	30	68	12
SGZ	17	M12X1,5	40	75	12
SGQ	17	M12X1,5	28	72	60°
SGW	17	M12X1,5	40	75	60°
483	17	M12X1,5	45	88	60°
583	17	M12X1,5	58	100	60°
SGK	17	M14X1,5	45	85	13
891A	17	M14X1,5	64	100	60°

NUT 60°
DADO 60°

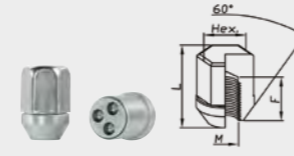

REF.	HEX.	M	F	L
HA2	17	M12X1,5	21	30
H	19	M12X1,5	26	34
HA	19	M12X1,5	21	30
170	19	M12X1,5	26	34
490R	19	M12X1,5	25	38
H1	21	M12X1,5	26	34
HL	21	M12X1,5	32	48
HA1	21	M12X1,5	21	30
H2	22	M12X1,5	26	34
RA2	17	M12X1,25	21	30
R	19	M12X1,25	26	34
RA	19	M12X1,25	21	30
R1	21	M12X1,25	26	34
RA1	21	M12X1,25	21	30
AE	19	1/2" UNF	24	34
AE2	21	1/2" UNF	24	34
AE1	22	1/2" UNF	24	34
AD	19	M14X1,5	26	34
AD1	21	M14X1,5	26	34
192A	22	M14X1,5	27	34
S	19	7/16" UNF	26	34
QA	19	M10x1,25	22	30
Q	17	M10x1,25	22	30
AF	17	3/8" UNF	22	30
Q1	17	M10x1,5	22	30

RADIUS NUT
DADO RAGGIATO

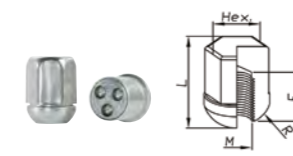

REF.	HEX.	M	F	L	R
AC	19	M12X1,25	22	30	12
AC1	19	M12X1,5	22	30	12
T	17	3/8" UNF	18	26	10
V	19	M14X1,5	25	34	12
V2	19	M14X1,5	24	24	12
V3	21	M14X1,5	24	24	12

CONICAL NUT WITH FLAT WASHER
DADO CONICO CON RONDELLA PIATTA

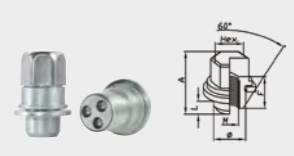

REF.	HEX.	M	ø	L	F	A
490	19	M12X1,5	18	13	25	38
F	19	M12X1,5	18,5	13	24	34
782	19	M12X1,5	18,5	10	24	34
462	19	M12X1,5	18,5	12	35	44
282	21	M12X1,5	18,5	10	24	34
482	21	M12X1,5	18,5	12	35	44
382	21	M12X1,5	18,5	12	25	36
AG4	22	M14X1,5	20	20	32	40
392	22	M14X1,5	22	11,5	32	42
TE	19	1/2" UNF	21,5	17	25	33

FLAT BOLT WITH DIAMETER
BULLONE PIATTO CON DIAMETRO

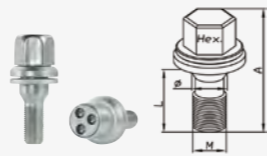

REF.	HEX.	M	ø	L	A
ZH4	17	M12X1,25	17	36	55
AH4	19	M12X1,25	17	36	55
VH4	21	M12X1,25	17	36	55
AH6	17	M12X1,5	18,5	33	53

FLAT BOLT WITH WASHER
BULLONE PIATTO CON RONDELLA

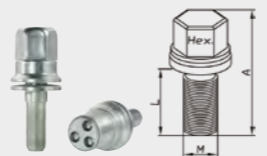

REF.	HEX.	M	L	A
ZH1	17	M12X1,25	35	61
ZH2	17	M12X1,25	35	68
ZH3	17	M12X1,25	35	84
AH1	19	M12X1,25	35	61
AH2	19	M12X1,25	35	68
AH3	19	M12X1,25	35	84
AH	19	M12X1,25	43	69
AH5	19	M12X1,25	67	86

BOLT WITH SPHERIC WASHER
BULLONE CON RONDELLA SFERICA

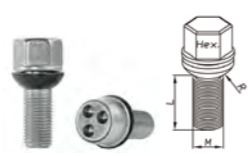

REF.	HEX.	M	L	R
AL3/R	19	M14X1,5	36	14

RADIUS NUT + CONICAL
DADO RAGGIATO CONICO

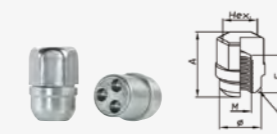

REF.	HEX.	M	ø	F	A	R
689	21	1/2" UNF Dx - SX	19,2	25	37	12
AG3	22	M12X1,5	21,5	26	34	12

CONICAL NUT + CYLINDRICAL 60°
DADO CONICO + CILINDRICO 60°

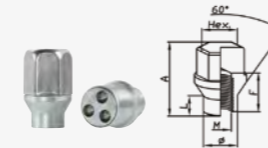

REF.	HEX.	M	ø	L	F	A
T7	19	M12X1,25	16	7	27	34
T9	19	M12X1,25	18	12,5	30	42
979	19	M12X1,25	17,5	28	32	52
076	19	M12X1,5	16	12,5	27	34
T6	19	M12X1,5	16	7	27	34
T61	21	M12X1,5	16	7	27	34
682	21	M12X1,5	17,7	33	36	54
476	21	M12X1,5	17,5	7	26	35
576	21	M12X1,5	17,5	28	32	52
690B	21	M12X1,5	17,5	16	34	44
389A	19	1/2" UNF	17	12	29	38

FLAT NUT
DADO PIATTO

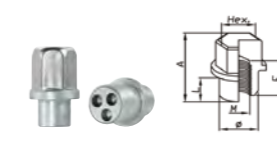

REF.	HEX.	M	ø	L	F	A
AB	19	M12X1,25	19	3	17	26
179	19	M12X1,25	17	13	27	40
279	21	M12X1,25	17	13	27	40
379	21	M12X1,25	19	13	27	40
PA	19	M12X1,5	17	14	28	37
390	19	M12X1,5	16	19	28	42
690	19	M12X1,5	17,5	19	28	42
790	19	M12X1,5	17,3	30	28	53
890	19	M12X1,5	17,5	44	28	67
990	19	M12X1,5	17,5	35	28	58
290	21	M12X1,5	17	14	28	37
690A	21	M12X1,5	17	19	30	42
990A	21	M12X1,5	17	35	30	58
789	19	1/2" UNF	17,5	19	27	42
889	19	1/2" UNF	17,5	30	27	53
989	19	1/2" UNF	17,5	44	27	67
489	21	1/2" UNF	17,5	10	27	37
289	22	1/2" UNF	17,5	10	27	37
168	17	3/8" UNF	15	11	27	33
368	17	3/8" UNF	14	19	35	41
468	17	3/8" UNF	14	30	46	52
172	19	7/16" UNF	16	19	28	42
272	19	7/16" UNF	16	30	28	53
372	19	7/16" UNF	16	44	28	67
472	19	7/16" UNF	17,5	19	28	42
572	19	7/16" UNF	17,5	30	28	43
672	19	7/16" UNF	17,5	44	28	67
772	22	7/16" UNF	19	13	28	36

NUT 60° WITH WASHER
DADO 60° CON RONDELLA

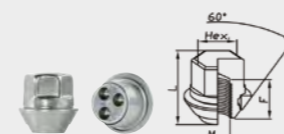

REF.	HEX.	M	F	L
280	19	M12X1,5	22	30

Locky

The design of the Locky wheel lock is made to withstand very high levels of torque. This wheel lock is perfect for wheels with small lightweight nuts with open hole. The Locky wheel lock fits all original equipment and aftermarket wheels on all cars (European, Asian and American cars etc). The combinations on the head of the wheel locks are protected by hexagonal stainless steel caps which make the wheel lock bright and attractive on your wheels.

- The wheel lock key's hexagon permits also the use of the key given by the car manufacturer
- Head cut resistant and perforation-proof
- Bolt's body class resistance 10.9 and nut's body class resistance 10
- Thread made after heat treatment
- Available for all cars
- Possibility to obtain a new key in case of loss

La tipologia di combinazione lo rende molto resistente alla torsione ed è particolarmente indicato come antifurto per dadi molto piccoli e leggeri con foro passante. Il bullone antifurto è disponibile per tutte le vetture europee, asiatiche e americane per le ruote in lega e non originali. Le combinazioni sono protette da un tappo esagonale in acciaio inox, che rende l'aspetto finale dell'antifurto brillante e molto gradevole quando viene montato sulla ruota.

- Esagono della chiave antifurto che permette l'utilizzo della chiave in dotazione con la vettura
- Testa a prova di perforazione e taglio
- Corpo in classe di resistenza 10.9 (bulloni) e con classe di resistenza 10 (dadi)
- Filettatura eseguita dopo bonifica
- Disponibile per tutti i tipi di vettura
- Possibilità di ottenere la chiave di ricambio in caso di perdita



BOLT 60°
BULLONE 60°

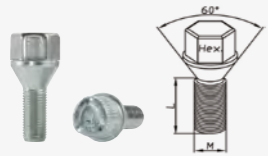

REF.	HEX.	M	L
B63	17	M14X1,5	25
B64	17	M14X1,5	27
B65	17	M14X1,5	30
B66	17	M14X1,5	35
B67	17	M14X1,5	50
B68	17	M14X1,5	40
B69	17	M14X1,5	45
B73	19	M14X1,5	25
B74	19	M14X1,5	27
B75	19	M14X1,5	30
B76	19	M14X1,5	35
B85	24	M14X1,5	30
B35	21	M14X1,5	30
BN1/C	17	M14X1,25	28
B90	24	M16X1,5	32
B91	21	M16X1,5	32
B99	19	M16X1,5	32
B100	22	M16X1,5	32
BG1	19	M12X1,75	25
BG2	19	M12X1,75	28
BV2	17	M12X1,25	22
BV3	17	M12X1,25	26
BV5	17	M12X1,25	31
BV6	17	M12X1,25	35
BV7	17	M12X1,25	40
BV8	17	M12X1,25	45
BV9	17	M12X1,25	50
B02	19	M12X1,25	22
B03	19	M12X1,25	26
B04	19	M12X1,25	31
B05	19	M12X1,25	31
B06	19	M12X1,25	35
B07	19	M12X1,25	40
B08	19	M12X1,25	45
B09	19	M12X1,25	50
B11	17	M12X1,5	20
B12	17	M12X1,5	23
B13	17	M12X1,5	25
B15	17	M12X1,5	30
B16	17	M12X1,5	35
B17	17	M12X1,5	40
B18	17	M12X1,5	45
B20	17	M12X1,5	50
B21	19	M12X1,5	20
B22	19	M12X1,5	23
B23	19	M12X1,5	25
B25	19	M12X1,5	30
B26	19	M12X1,5	35
B27	19	M12X1,5	40

RADIUS BOLT
BULLONE RAGGIATO

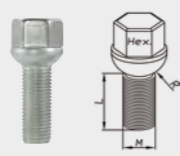

REF.	HEX.	M	L	R
B53	17	M14X1,5	25	13
B54	17	M14X1,5	28	13
B55	17	M14X1,5	30	13
B56	17	M14X1,5	35	13
B57	17	M14X1,5	40	13
B58	17	M14X1,5	45	13
B88	17	M14X1,5	50	13
B86	17	M14X1,5	55	13
B87	17	M14X1,5	60	13
B59	17	M14X1,5	70	13
B93	19	M14X1,5	25	13
B92	19	M14X1,5	28	13
B95	19	M14X1,5	30	13
B96	19	M14X1,5	35	13
B97	19	M14X1,5	40	13
B94	19	M14X1,5	45	13
B98	19	M14X1,5	52	13
B41	17	M12X1,5	20	12
B42	17	M12X1,5	24	12
B44	17	M12X1,5	28	12
B45	17	M12X1,5	31	12
B46	17	M12X1,5	35	12
B47	17	M12X1,5	40	12
B48	17	M12X1,5	45	12
B49	17	M12X1,5	50	12
B50	17	M12X1,5	56	12

FLAT BOLT WITH DIAMETER
BULLONE PIATTO CON DIAMETRO

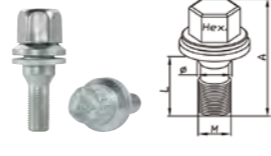

REF.	HEX.	M	ø	L	A
BB8	19	M12X1,25	17	36	63
BE8	17	M12X1,25	17	36	63
BDB	21	M12X1,25	17	36	63
BC4	17	M12X1,5	18,5	33	53

NUT 60°
DADO 60°

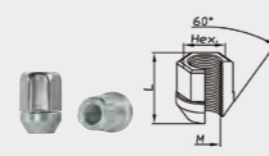

REF.	HEX.	M	L
D6	17	M12X1,5	27
D1	19	M12X1,5	27
D2	19	M12X1,5	34
D37	19	M12X1,5	21
D3	21	M12X1,5	27
D4	21	M12X1,5	34
D27	21	M12X1,5	21
D47	17	M12X1,25	21
D15	17	M12X1,25	27
D16	17	M12X1,25	34
D11	19	M12X1,25	27
D12	19	M12X1,25	34
D57	19	M12X1,25	21
D13	21	M12X1,25	27
D14	21	M12X1,25	34
D17	21	M12X1,25	21
D59	19	1/2" UNF	27
D60	19	1/2" UNF	34
D61	22	1/2" UNF	34
D71	19	7/16" UNF	27
D81	19	7/16" UNF	34
D75	17	3/8" UNF	27
D32	19	M14X1,5	34
D33	17	M14X1,5	26
D31	19	M14X1,5	26
D51	21	M14X1,5	26
D62	21	M14X1,5	34
D63	22	M14X1,5	26
DD1	27	M16X1,5	25

CONICAL NUT + CYLINDRICAL 60°
DADO CONICO + CILINDRICO 60°

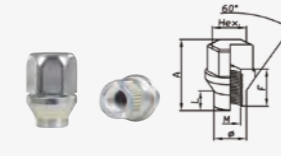

REF.	HEX.	M	ø	L	F	A
TL6	19	M12X1,25	15,5	4,5	33	33
TL4	19	M12X1,25	15,5	7	28	28
TL15	19	M12X1,25	17	12	43	43
TL3	21	M12X1,25	15,5	7	28	28
TL7	21	M12X1,25	15,5	4,5	33	33
TL10	21	M12X1,25	15,5	4,5	25	38
TL12	21	M12X1,25	17	12	43	43
TL1	19	M12X1,5	15,5	7	28	28
TL8	19	M12X1,5	15,5	4,5	33	33
TL14	19	M12X1,5	17	12	43	43
TL2	21	M12X1,5	15,5	7	28	28
TL9	21	M12X1,5	15,5	4,5	33	33
TL11	21	M12X1,5	17	12	43	43
TL5	19	1/2" UNF	15,5	7	28	28

RADIUS NUT
DADO RAGGIATO

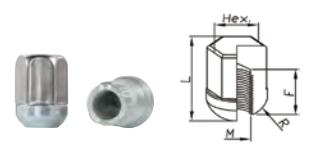

REF.	HEX.	M	F	L	R
D21	17	M12X1,5	25	25	12
D22	19	M12X1,5	25	25	12
D5	21	M12X1,5	25	25	12
D7	22	M12X1,5	25	25	12
D82	21	M12X1,25	25	25	12
D43	19	M14X1,5	24	24	12
D42	19	M14X1,5	32	32	12
D44	21	M14X1,5	24	24	12
D45	22	M14X1,5	24	24	12

CONICAL OR RADIUS BOLT WITH LONG HEAD
BULLONE CONICO O RAGGIATO CON TESTA ALLUNGATA

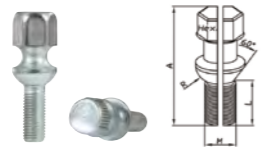

REF.	HEX.	M	L	A	SEDE
BM5	17	M12X1,5	30	68	R
BM8	17	M12X1,5	39	74	R
BM9	17	M14X1,5	45	85	R

FLAT BOLT WITH WASHER
BULLONE PIATTO CON RONDELLA

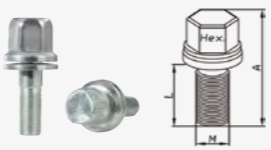

REF.	HEX.	M	L	A
BF6	17	M12X1,25	35	61
BE6	17	M12X1,25	35	69
BE7	17	M12X1,25	35	87
BA6	19	M12X1,25	35	69
BB6	19	M12X1,25	35	61
BX8	19	M12X1,25	43	67
BB7	19	M12X1,25	35	87

NUT 60° WITH WASHER
DADO 60° CON RONDELLA

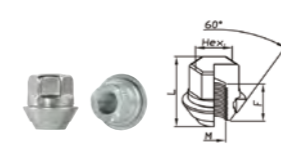

REF.	HEX.	M	F	L
DA1	19	M12X1,5	27	27
DA5	19	M12X1,25	27	27

CONICAL NUT WITH FLAT WASHER
DADO CONICO CON RONDELLA PIATTA

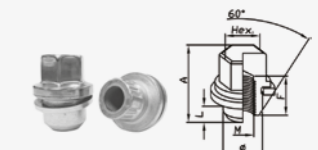

REF.	HEX.	M	ø	L	F	A
DD3	27	M14X1,5	29	18,5	30	47
DD2	27	M16X1,5	29	18,5	30	47

BOLT INER-AXE VARIATION
BULLONE VARIAZIONE INTERASSE

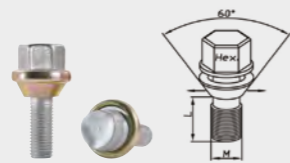

REF.	HEX.	M	L
BZ5	17	M12X1,25	27
BZ6	17	M12X1,25	30
BZ8	17	M12X1,25	34
BZ2	19	M12X1,25	30
BZ4	19	M12X1,25	34
BZ9	19	M12X1,25	27
BZ3	17	M12X1,5	30
BZ7	19	M12X1,5	30

BOLT 60° WITH WASHER
BULLONE CON RONDELLA 60°

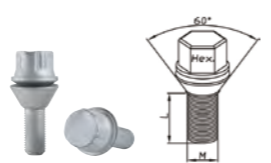

REF.	HEX.	M	L
BF2	24	M14X1,5	34
BF3	24	M16X1,5	34

Locket

Locket is a universal wheel lock which covers the 98% of the European car market. The combinations on the head of the wheel locks are protected by hexagonal stainless steel caps which make the wheel lock bright and attractive on your wheels.

- The wheel lock key's hexagon permits also the use of the key given by the car manufacturer
- Bolt's body class resistance 10.9 and nut's body class resistance 10
- Thread made after heat treatment
- Available for all cars
- Possibility to obtain a new key in case of loss

Progettato come bullone antifurto universale, ricopre il 98% della gamma di vetture esistenti sul mercato europeo. Le combinazioni sono protette da un tappo esagonale in acciaio inox che rende l'aspetto finale dell'antifurto brillante e gradevole quando viene montato sulla ruota.

- Esagono della chiave antifurto che permette l'utilizzo della chiave in dotazione con la vettura
- Corpo in classe di resistenza 10.9 (bulloni) e con classe di resistenza 10 (dadi)
- Filettatura eseguita dopo bonifica
- Disponibile per tutti i tipi di vettura
- Possibilità di ottenere la chiave di ricambio in caso di perdita



FLAT BOLT WITH DIAMETER
BULLONE PIATTO CON DIAMETRO

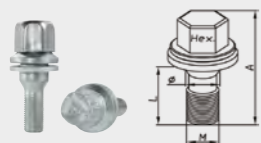

REF.	HEX.	M	ø	L	A
DB10	19/17	M12X1,25	17	36	63

NUT 60° WITH WASHER
DADO 60° CON RONDELLA

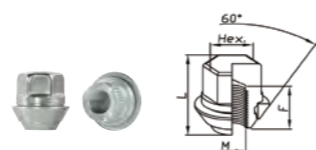

REF.	HEX.	M	F	L
DB6	19	M12X1,5	27	27

FLAT BOLT WITH WASHER
BULLONE PIATTO CON RONDELLA

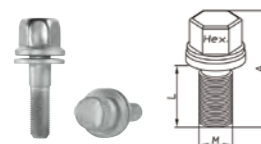

REF.	HEX.	M	L	A
BB6	19	M12X1,25	35	61

RADIUS NUT
DADO RAGGIATO

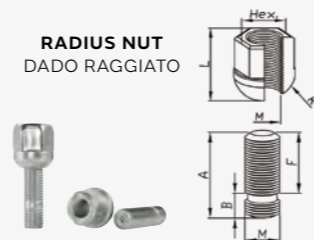

REF.	HEX.	M	L	R	A	B	F
DB3	17	M12X1,5	25	12	50	11	35
DB4	17	M14X1,5	24	12	50	11	35

NUT 60°
DADO 60°



REF.	HEX.	M	L	A	B	F
DB2	19/17	M12X1,5	27	50	11	35
DB1	19/17	M12X1,25	27	50	11	35
DB5	17	M14X1,5	26	50	11	35



MICROLOCK

MICROLOCK

Wheel lock to protect alloy wheels with little holes up to 21 mm of diameter.

- The combination's design prevents the extraction with tools available on the market
- Impossible to pierce the bolt's or nut's head
- The bolt's body class resistance is 10.9 and the nut's body class resistance is 10
- Compact design

Viti antifurto per proteggere le ruote in lega con i fori piccoli di diametro fino a 21 mm.

- La struttura della combinazione antifurto impedisce lo svitamento con l'utilizzo di utensili disponibili sul mercato
- Testa del bullone o dado a prova di perforazione
- Corpo in classe di resistenza 10.9 (bulloni) e classe di resistenza 10 (dadi)
- Design compatto



BOLT 60°
BULLONE 60°

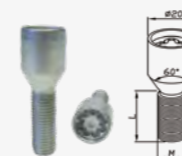

REF.	HEX.	M	L
I3/J	17/19	M12X1,5	22
I/J	17/19	M12X1,5	26
I1/J	17/19	M12X1,5	30
I2/J	17/19	M12X1,5	33
I7/J	17/19	M12X1,5	38
SA/J	17/19	M12X1,5	41
SA2/J	17/19	M12X1,5	45
K/J	17/19	M12X1,25	25
E1/J	17/19	M12X1,25	31
E/J	17/19	M12X1,25	35
SH/J	17/19	M12X1,25	41
C1/J	17/19	M14X1,5	25
C2/J	17/19	M14X1,5	30
C5/J	17/19	M14X1,5	35
C4/J	17/19	M14X1,5	40
C3/J	17/19	M14X1,5	45
N/J	17/19	M14x1,25	27
N1/J	17/19	M14x1,25	28
N2/J	17/19	M14x1,25	30
N3/J	17/19	M14x1,25	35
N4/J	17/19	M14x1,25	40
N5/J	17/19	M14x1,25	45

NUT 60°
DADO 60°

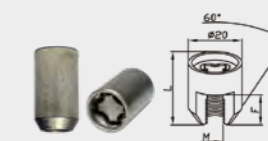

REF.	HEX.	M	F	L
H/J	17/19	M12X1,5	22	36
R/J	17/19	M12X1,25	22	36
AD/J	17/19	M14X1,5	22	36

CONICAL NUT + CYLINDRICAL 60°
DADO CONICO + CILINDRICO 60°

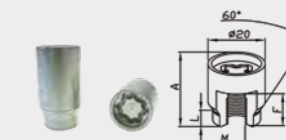

REF.	HEX.	M	ø	L	F	A
T6/J	17/19	M12X1,5	16	7	27	38
T7/J	17/19	M12X1,25	16	7	27	38

TRUCKLOCK

THE TRUCKLock is very simple to install and it is the ideal and safest solution to protect the vans' wheels from any kind of theft.

- **The key can be easily inserted and taken out of the lock thanks to its automatic centering system**
- **The wheel lock key's hexagon permits the use of the key given by the truck manufacturer**
- **Strong rotary anti-cutting ring which doesn't allow other tools to unscrew it**
- **Perforation-proof head**
- **The bolt's body class resistance is 10**
- **The wheel lock prevents the unscrewing of the original nut**
- **Available for all trucks**
- **Patented**
- **The combination's design prevents the extraction with tools available on the market**
- **Perforation-proof head**

Molto sicuro e facile da montare, il TruckLock è la soluzione ideale per proteggere le ruote dei camion da qualsiasi tipo di furto.

- Chiave autocentrante per un facile montaggio e smontaggio
- L'esagono della chiave antifurto permette l'utilizzo della chiave delle ruote originali del camion
- Robusto anello rotante anti taglio che impedisce lo svitamento con utensili disponibili sul mercato
- Testa a prova di perforazione
- Corpo con classe di resistenza 10
- L'antifurto impedisce lo svitamento del dado originale
- Disponibile per tutti i tipi di camion
- Brevettato
- La struttura della combinazione antifurto impedisce lo svitamento con l'utilizzo di utensili disponibili sul mercato
- Testa a prova di perforazione



AVAILABLE FOR STEEL WHEELS
DISPONIBILI PER RUOTE IN ACCIAIO

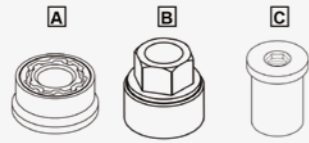

	A		B		C
TIPO	FILETTO	TIPO	ESAGONO	OPTIONAL	
LA8/L	M18x1,5	CH27P/L	27	DC18 /L	
LA7/L	M20x1,5	CH30/L	30	DC20 /L	
LA3/L	M22x1,5	CH32/L	32	DC22 /L	
LA6/L	M22x1,5	CH33/L	33	DC22 /L	
DS4/H	M16x1,5	CH35/L	22	-	
LA5/L	7/8-14UNF	CH33/L	33	DC25/L	
LA4/L	7/8-11BSF	CH33/L	33	DC24 /L	

AVAILABLE FOR ORIGINAL ALLOY WHEELS
DISPONIBILI PER RUOTE IN LEGA

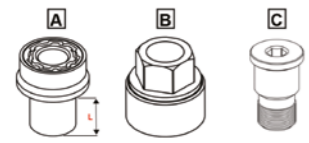

	A		B		C
TIPO	FILETTO	L	TIPO	ESAGONO	OPTIONAL
LA1/L	M22x1,5	12	CH32/L	32	PTR/L
LA2/L	M22x1,5	35	CH32/L	32	PTR/L

HOW TO ORDER THE WHEEL LOCKS FOR YOUR TRUCK
COME ORDINARE L'ANTIFURTO RUOTE IN BASE AL PROPRIO CAMION

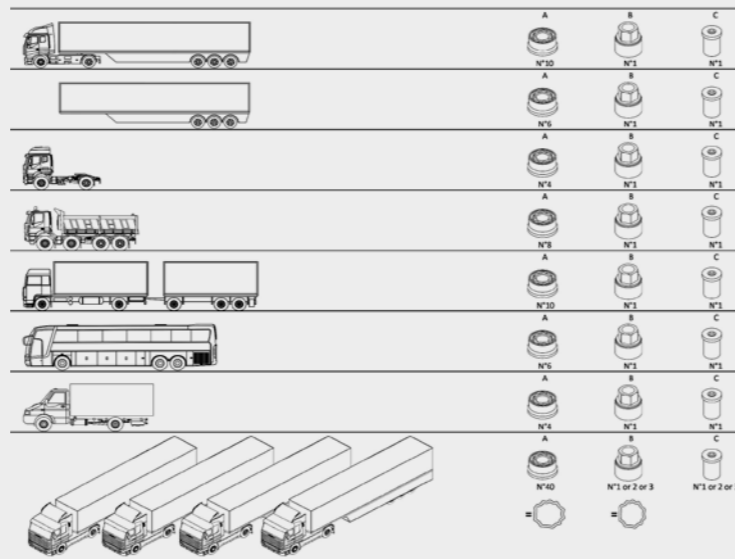

IT IS POSSIBLE TO ORDER THE SAME COMBINATION FOR ALL YOUR TRUCKS
E' POSSIBILE AVERE LA STESSA COMBINAZIONE PER TUTTI I VOSTRI CAMION

FOR STEEL WHEELS
PER CERCHI IN ACCIAIO

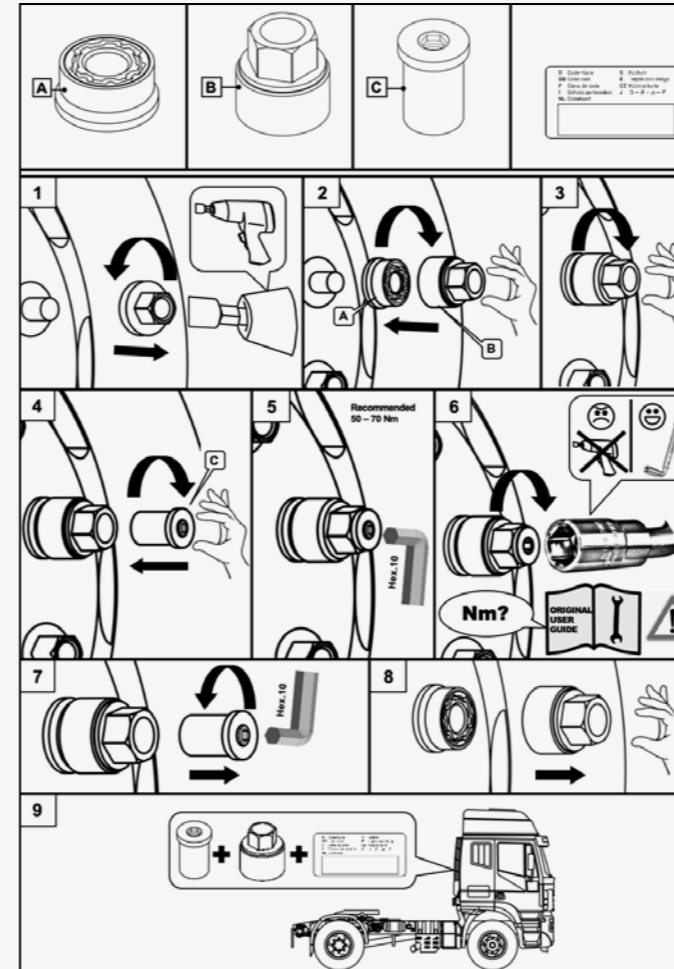

FOR STEEL ALLOY
PER CERCHI IN LEGA

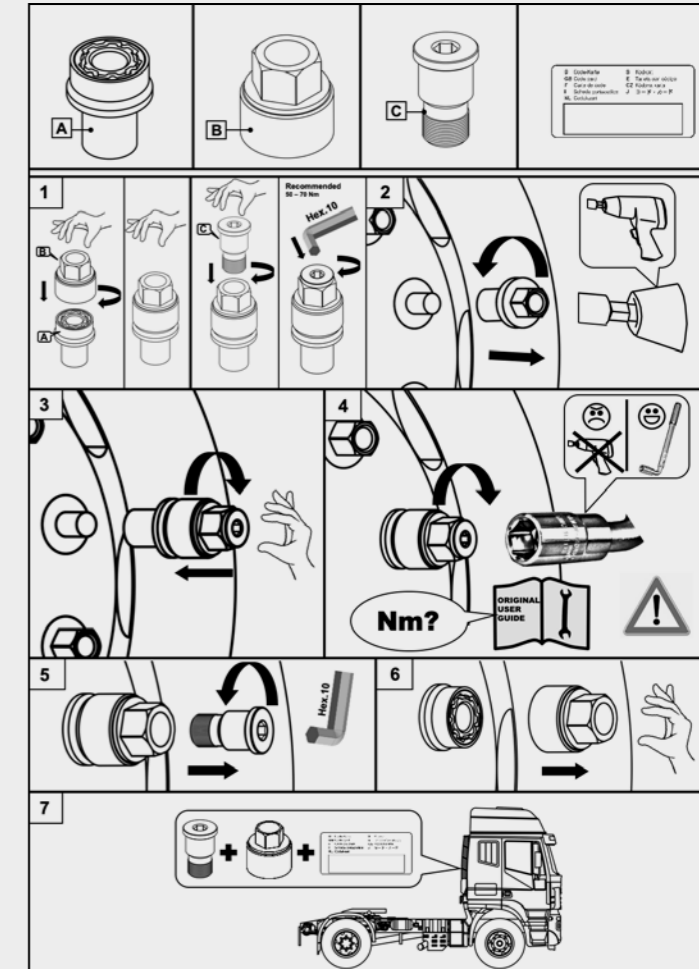

ROOF BARS
BARRE PORTATUTTO

**EASY FITTING, ELEGANCE AND SAFETY:
THESE ARE THE KEY WORDS FOR FARAD ROOF BARS.**

ESTREMA FACILITÀ DI MONTAGGIO, ELEGANZA E SICUREZZA
SONO LE PAROLE CHIAVE DELLE BARRE FARAD.



FARAD[®]
made in Italy



PREASSEMBLED



BEAMAR PREASSEMBLED

LENGTH CM LUNGHEZZA CM						BAR HEIGHT MM ALTEZZA BARRA MM	MAXIMUM LOAD KG CARICO MASSIMO KG	FIXING SYSTEM REQUIRED KIT DI FISSAGGIO RICHIESTO	NO TOOLS REQUIRED MONTAGGIO SENZA UTENSILI	LOCKING SYSTEM INCLUDED SERRATURA INCLUSA
100	110	120	130	140	160	56	100		✓	✓
	✓	✓	✓							



SIME PREASSEMBLED

LENGTH CM LUNGHEZZA CM						BAR HEIGHT MM ALTEZZA BARRA MM	MAXIMUM LOAD KG CARICO MASSIMO KG	FIXING SYSTEM REQUIRED KIT DI FISSAGGIO RICHIESTO	NO TOOLS REQUIRED MONTAGGIO SENZA UTENSILI	LOCKING SYSTEM INCLUDED SERRATURA INCLUSA
100	110	120	130	140	160	51	100		✓	✓
	✓	✓	✓	✓	✓					



HILOPLUS PREASSEMBLED

LENGTH CM LUNGHEZZA CM		BAR HEIGHT MM ALTEZZA BARRA MM	MAXIMUM LOAD KG CARICO MASSIMO KG	FIXING SYSTEM REQUIRED KIT DI FISSAGGIO RICHIESTO	NO TOOLS REQUIRED MONTAGGIO SENZA UTENSILI
SHORT CORTA	LONG LUNGA				
76 > 113	104 > 136,5	90	75	✓	✓

IRON ROOF BARS



IRON IRON 2

LENGTH CM LUNGHEZZA CM						BAR HEIGHT MM ALTEZZA BARRA MM	MAXIMUM LOAD KG CARICO MASSIMO KG	FIXING SYSTEM REQUIRED KIT DI FISSAGGIO RICHIESTO	NO TOOLS REQUIRED MONTAGGIO SENZA UTENSILI
100	110	120	130	140	160	27	75	✓	✓
✓	✓	✓	✓	✓					



IRON TELESCOPIC IRON 3

LENGTH CM LUNGHEZZA CM		BAR HEIGHT MM ALTEZZA BARRA MM	MAXIMUM LOAD KG CARICO MASSIMO KG	FIXING SYSTEM REQUIRED KIT DI FISSAGGIO RICHIESTO	NO TOOLS REQUIRED MONTAGGIO SENZA UTENSILI
SHORT CORTA	LONG LUNGA				
76 > 113	104 > 136,5	27	75	✓	✓



IRONQUADRA IRON 4

LENGTH CM LUNGHEZZA CM						BAR HEIGHT MM ALTEZZA BARRA MM	MAXIMUM LOAD KG CARICO MASSIMO KG	FIXING SYSTEM REQUIRED KIT DI FISSAGGIO RICHIESTO	NO TOOLS REQUIRED MONTAGGIO SENZA UTENSILI
100	110	120	130	140	160	22	75	✓	✓
✓	✓	✓	✓						

ALUMINIUM ROOF BARS



ALUMINIUM

LENGTH CM LUNGHEZZA CM						BAR HEIGHT MM ALTEZZA BARRA MM	MAXIMUM LOAD KG CARICO MASSIMO KG	FIXING SYSTEM REQUIRED KIT DI FISSAGGIO RICHIESTO	NO TOOLS REQUIRED MONTAGGIO SENZA UTENSILI
100	110	120	130	140	160	27	100	✓	✓
✓	✓	✓	✓	✓	✓				



AERODYNAMIC SILVER

LENGTH CM LUNGHEZZA CM						BAR HEIGHT MM ALTEZZA BARRA MM	MAXIMUM LOAD KG CARICO MASSIMO KG	FIXING SYSTEM REQUIRED KIT DI FISSAGGIO RICHIESTO	NO TOOLS REQUIRED MONTAGGIO SENZA UTENSILI
100	110	120	130	140	160	27	100	✓	✓
✓	✓	✓	✓	✓					



AERODYNAMIC BLACK

LENGTH CM LUNGHEZZA CM						BAR HEIGHT MM ALTEZZA BARRA MM	MAXIMUM LOAD KG CARICO MASSIMO KG	FIXING SYSTEM REQUIRED KIT DI FISSAGGIO RICHIESTO	NO TOOLS REQUIRED MONTAGGIO SENZA UTENSILI
100	110	120	130	140	160	27	100	✓	✓
✓	✓	✓	✓	✓					

UNIVERSAL KIT

COMPATIBLE WITH ALL BARS
COMPATIBILI CON TUTTE LE BARRE



KIT HILO
FOR CARS WITH HIGH AND INTEGRATED ROOF RAILS
PER AUTO CON CORRIMANO ALTO E BASSO

CLASSIC KIT

NOT COMPATIBLE WITH IRON 4
NON COMPATIBILI CON IRON 4



KIT SM
FOR CARS WITH HIGH ROOF RAILS
PER AUTO CON CORRIMANO ALTO



KIT BM
FOR CARS WITH INTEGRATED ROOF RAILS
PER AUTO CON CORRIMANO BASSO



KIT BS
SPECIFIC KIT FOR CARS WITHOUT ROOF RAILS
KIT SPECIFICO PER AUTO SENZA CORRIMANO

SMART KIT

COMPATIBLE WITH ALL BARS
COMPATIBILI CON TUTTE LE BARRE



FOR CARS WITH HIGH ROOF RAILS
PER AUTO CON CORRIMANO ALTO



FOR CARS WITH INTEGRATED
ROOF RAILS
PER AUTO CON CORRIMANO BASSO



FOR CARS WITHOUT ROOF RAILS
WITH FIX POINTS
PER AUTO SENZA CORRIMANO
CON PREDISPOSIZIONE



FOR CARS WITHOUT ROOF RAILS
WITH FIX POINTS
PER AUTO SENZA CORRIMANO
CON PREDISPOSIZIONE



SPECIFIC KIT FOR CARS
WITHOUT ROOF RAILS
KIT SPECIFICO PER AUTO
SENZA CORRIMANO

COMPACT BARS



COMPACT SILVER

COMPACT BLACK

LENGTH CM LUNGHEZZA CM								BAR HEIGHT MM ALTEZZA BARRA MM	MAXIMUM LOAD KG CARICO MASSIMO KG	FIXING SYSTEM REQUIRED KIT DI FISSAGGIO RICHIESTO	NO TOOLS REQUIRED MONTAGGIO SENZA UTENSILI
70 - 70	70 - 80	80 - 80	80 - 90	90 - 90	90 - 100	100 - 100	100 - 110				
✓	✓	✓	✓	✓	✓	✓	✓	105	100	✓	✓

COMPACT + KIT



COMPATIBLE WITH ALL KITS
COMPATIBILI CON TUTTI I KIT



COMPACT + KIT HX FOR CARS WITH HIGH ROOF RAILS - PER AUTO CON CORRIMANO ALTO



COMPACT + KIT LX FOR CARS WITH INTEGRATED ROOF RAILS - PER AUTO CON CORRIMANO BASSO



COMPACT + KIT PR FOR CARS WITHOUT ROOF RAILS WITH FIX POINTS - PER AUTO SENZA CORRIMANO CON PREDISPOSIZIONE



COMPACT + KIT PK FOR CARS WITHOUT ROOF RAILS WITH FIX POINTS - PER AUTO SENZA CORRIMANO CON PREDISPOSIZIONE



COMPACT + KIT SX SPECIFIC KIT FOR CARS WITHOUT ROOF RAILS - KIT SPECIFICO PER AUTO SENZA CORRIMANO

COMMERCIAL BARS



SET FOR 2 BARS
SET FOR 3 BARS

NEW

ALU PACK

					BAR HEIGHT MM ALTEZZA BARRA MM	MAXIMUM LOAD KG CARICO MASSIMO KG	FIXING SYSTEM REQUIRED KIT DI FISSAGGIO RICHIESTO	NO TOOLS REQUIRED MONTAGGIO SENZA UTENSILI
130	140	150	160	180	44	100	✓	✓
✓	✓	✓	✓	✓				

KITS & ACCESSORIES

SUITABLE FOR ALU PACK, ALUMINIUM OR IRON ROOF BARS: - ALUMINIUM, 130, 140, 160 -IRON 2, 120, 130, 140 -IRON 4, 120, 130



SET FOR 2 BARS
SET FOR 3 BARS

KIT AC

FIXING KIT FOR BARS FOR VANS
KIT DI FISSAGGIO PER BARRE VEICOLI COMMERCIALI



SET FOR 2 BARS
SET FOR 3 BARS

LOAD STOP

LOAD STOP
SPONDINA FERMACARICO



SHORT 50cm
LONG 100cm

ROLLER

LOADING ROLLER
RULLO DA CARICO



EXTENDER ROLLER

ROLLER ADJUSTABLE BRACKET
STAFFE REGOLAZIONE RULLO



ROOF BOXES

BAULI

**HIGH QUALITY, MODERN DESIGN
AND ELEGANT FINISHING MAKE FARAD ROOF BOXES
YOUR IDEAL TRAVEL COMPANION.
THANKS TO THE WIDE CHOICE OF COLORS,
DIMENSIONS AND STYLE,
YOU CAN EASILY FIND THE CORRECT PRODUCT
TO FIT YOUR NEEDS.**

ALTISSIMA QUALITÀ, DESIGN MODERNO
E FINITURE DI PRESTIGIO FANNO DEL BAULE FARAD
IL COMPAGNO FIDATO DI OGNI VIAGGIO.
GRAZIE ALLA VASTA GAMMA, NON SARÀ UN PROBLEMA
TROVARE IL PRODOTTO DI COLORE, DIMENSIONE
E STILE PIÙ ADATTO ALLE VOSTRE ESIGENZE.



FARAD[®]
made in Italy

RAYA



**TRAVEL WITHOUT LIMITS
WITH THE NEW RAYA ROOF BOX:
ORGANIZE EVERYTHING YOU NEED
AND PROTECT YOUR BELONGINGS
WITH COMPLETE SECURITY.
ENJOY EVERY ADVENTURE
WITHOUT WORRIES!**

VIAGGIA SENZA LIMITI CON IL NUOVO BOX RAYA:
ORGANIZZA TUTTO CIÒ DI CUI HAI BISOGNO
E PROTEGGI I TUOI OGGETTI IN TOTALE SICUREZZA.
GODITI OGNI AVVENTURA SENZA PREOCCUPAZIONI!

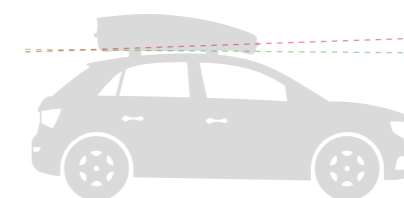

**The bottom line of the box was designed
to increase the aerodynamics**
La linea del box è stata progettata
per aumentare la aerodinamica



Double-side opening
Doppia apertura



Quick fix
Fissaggio rapido



Compass opening
Apertura con compasso meccanico



Safety locking system
Chiave antifurto







Three point centralized closure
Chiusura centralizzata in tre punti

RAYA



	LITRES LITRI	OUTER DIMENSIONS CM DIMENSIONI ESTERNE CM	INNER DIMENSIONS CM DIMENSIONI INTERNE CM	MAXIMUM LOAD FOR CARS KG CARICO MASSIMO PER AUTO KG	MAXIMUM LOAD FOR MOTOR HOMES KG CARICO MASSIMO PER CAMPER KG	WEIGHT KG PESO KG	FIXING SYSTEM: STANDARD U BOLT FITTING SISTEMA DI FISSAGGIO: FISSAGGIO STANDARD CON CAVALLOTTO A U	MIN/MAX DISTANCE BETWEEN BARS CM DISTANZA MIN/MAX TRA LE BARRE CM	CENTRAL LOCKING CHIUSURA CENTRALIZZATA	DOUBLE-SIDE OPENING DOPPIA APERTURA	FIXING BELTS CINGHIE DI FISSAGGIO	5 YEARS WARRANTY GARANZIA 5 ANNI
TYPE N.25	480	190X80X42	182X74X37	75	75	14	✓	48,5/112,5	✓	✓	✓	✓

	MATTE GREY GRIGIO GOFFRATO	METALLIC GREY GRIGIO METALLIZZATO	GLOSSY BLACK NERO LUCIDO	MATTE BLACK NERO GOFFRATO	GLOSSY WHITE BIANCO LUCIDO
TYPE N.25					



KORAL



**THE NEW KORAL DESIGN,
MODERN AND APPEALING,
REDEFINES THE LINE OF YOUR CAR.**

IL NUOVO DESIGN KORAL,
MODERNO ED ACCATTIVANTE,
RIDEFINISCE LA LINEA DELLA TUA AUTO.



Double-side opening
Doppia apertura



Quick fix
Fissaggio rapido



Compass opening
Apertura con compasso meccanico



Safety locking system
Chiave antifurto



Three point centralized closure
Chiusura centralizzata in tre punti

KORAL



	LITRES LITRI	OUTER DIMENSIONS CM DIMENSIONI ESTERNE CM	INNER DIMENSIONS CM DIMENSIONI INTERNE CM	MAXIMUM LOAD FOR CARS KG CARICO MASSIMO PER AUTO KG	MAXIMUM LOAD FOR MOTOR HOMES KG CARICO MASSIMO PER CAMPER KG	WEIGHT KG PESO KG	FIXING SYSTEM: FARAD QUICK FIX SISTEMA DI FISSAGGIO: FARAD QUICK FIX	MIN/MAX DISTANCE BETWEEN BARS CM DISTANZA MIN/MAX TRA LE BARRE CM	CENTRAL LOCKING CHIUSURA CENTRALIZZATA	DOUBLE-SIDE OPENING DOPPIA APERTURA	FIXING BELTS CINGHIE DI FISSAGGIO	5 YEARS WARRANTY GARANZIA 5 ANNI
TYPE N.19	400	160X80X40	153X58	75	90	12	✓	36/94	✓	✓	✓	✓
TYPE N.20	480	190X80X40	182X72	75	90	14	✓	30/87	✓	✓	✓	✓
TYPE N.21	630	210X90X42	196X83	75	90	18	✓	39/99	✓	✓	✓	✓
TYPE N.23	400	145X95X43	135X86	75	90	15	✓	23/80	✓	✓	✓	✓

	MATTE GREY GRIGIO GOFFRATO	METALLIC GREY GRIGIO METALLIZZATO	GLOSSY BLACK NERO LUCIDO	MATTE BLACK NERO GOFFRATO	GLOSSY WHITE BIANCO LUCIDO
TYPE N.19					
TYPE N.20					
TYPE N.21					
TYPE N.23					

MARLIN



**FARAD MARLIN LINE
WITH ITS MODERN AND AERODYNAMIC
STYLE ALLOWS YOU
TO TRAVEL WITH ELEGANCE.**

LO STILE MARLIN,
CON IL SUO DESIGN MODERNO ED AERODINAMICO,
VI ACCOMPAGNA CON ELEGANZA
IN OGNI VOSTRO VIAGGIO.



Double-side opening
Doppia apertura



Quick fix
Fissaggio rapido



Compass opening
Apertura con compasso meccanico



Safety locking system
Chiave antifurto



















Three point centralized closure
Chiusura centralizzata in tre punti

MARLIN



	LITRES LITRI	OUTER DIMENSIONS CM DIMENSIONI ESTERNE CM	INNER DIMENSIONS CM DIMENSIONI INTERNE CM	MAXIMUM LOAD FOR CARS KG CARICO MASSIMO PER AUTO KG	MAXIMUM LOAD FOR MOTOR HOMES KG CARICO MASSIMO PER CAMPER KG	WEIGHT KG PESO KG	FIXING SYSTEM: FARAD QUICK FIX SISTEMA DI FISSAGGIO: FARAD QUICK FIX	MIN/MAX DISTANCE BETWEEN BARS CM DISTANZA MIN/MAX TRA LE BARRE CM	CENTRAL LOCKING CHIUSURA CENTRALIZZATA	DOUBLE-SIDE OPENING DOPPIA APERTURA	FIXING BELTS CINGHIE DI FISSAGGIO	5 YEARS WARRANTY GARANZIA 5 ANNI
TYPE N.6	480	190X80X40	184X73	75	90	15	✓	39 / 95	✓	✓	✓	✓
TYPE N.7	680	210X100X42	198X92	75	90	21	✓	55 / 110	✓	✓	✓	✓
TYPE N.8	400	160X80X40	154X73	75	90	13	✓	20 / 77	✓	✓	✓	✓
TYPE N.11	530	225X80X42	215X70	75	90	18	✓	52 / 108	✓	✓	✓	✓

	MATTE GREY GRIGIO GOFFRATO	METALLIC GREY GRIGIO METALLIZZATO	GLOSSY BLACK NERO LUCIDO	MATTE BLACK NERO GOFFRATO	GLOSSY WHITE BIANCO LUCIDO
TYPE N.6					
TYPE N.7					
TYPE N.8					
TYPE N.11					

DORY



**THE PERFECT
TRAVEL COMPANION
FOR YOUR NEW ADVENTURES.**

IL COMPAGNO DI VIAGGIO IDEALE
PER LE TUE NUOVE AVVENTURE.



Double-side opening
Doppia apertura



Standard U bolt fitting
Fissaggio standard con cavallotto a U



Compass opening
Apertura con compasso meccanico



Safety locking system
Chiave antifurto



Three point centralized closure
Chiusura centralizzata in tre punti

DORY



	LITRES LITRI	OUTER DIMENSIONS CM DIMENSIONI ESTERNE CM	INNER DIMENSIONS CM DIMENSIONI INTERNE CM	MAXIMUM LOAD FOR CARS KG CARICO MASSIMO PER AUTO KG	MAXIMUM LOAD FOR MOTOR HOMES KG CARICO MASSIMO PER CAMPER KG	WEIGHT KG PESO KG	FIXING SYSTEM: STANDARD U BOLT FITTING SISTEMA DI FISSAGGIO: FISSAGGIO STANDARD CON CAVALOTTO A U	MIN/MAX DISTANCE BETWEEN BARS CM DISTANZA MIN/MAX TRA LE BARRE CM	CENTRAL LOCKING CHIUSURA CENTRALIZZATA	DOUBLE-SIDE OPENING DOPPIA APERTURA	FIXING BELTS CINGHIE DI FISSAGGIO	5 YEARS WARRANTY GARANZIA 5 ANNI
TYPE N.22-1	340	140X75X39	134X69	75	90	12	✓	41 / 71	✓	✓	✓	✓
	MATTE GREY GRIGIO GOFFRATO											
	METALLIC GREY GRIGIO METALLIZZATO											
	GLOSSY BLACK NERO LUCIDO											
	MATTE BLACK NERO GOFFRATO											
	GLOSSY WHITE BIANCO LUCIDO											
TYPE N.22-1												



CRUB



**FARAD CRUB COMBINES
EASY MOUNTING
WITH THE SMART, MODERN
AND COMPACT DESIGN.**

LO STILE CRUB DEL BAULE FARAD,
UNISCE LA PRATICITÀ DEL MONTAGGIO
ALL'ASPETTO SMART,
MODERNO E COMPATTO.



Double-side opening
Doppia apertura



Standard U bolt fitting
Fissaggio standard con cavallotto a U



Compass opening
Apertura con compasso meccanico



Safety locking system
Chiave antifurto



Three point centralized closure
Chiusura centralizzata in tre punti

CRUB



	LITRES LITRI	OUTER DIMENSIONS CM DIMENSIONI ESTERNE CM	INNER DIMENSIONS CM DIMENSIONI INTERNE CM	MAXIMUM LOAD FOR CARS KG CARICO MASSIMO PER AUTO KG	MAXIMUM LOAD FOR MOTOR HOMES KG CARICO MASSIMO PER CAMPER KG	WEIGHT KG PESO KG	FIXING SYSTEM: STANDARD U BOLT FITTING SISTEMA DI FISSAGGIO: FISSAGGIO STANDARD CON CAVALLOTTO A U	MIN/MAX DISTANCE BETWEEN BARS CM DISTANZA MIN/MAX TRA LE BARRE CM	CENTRAL LOCKING CHIUSURA CENTRALIZZATA	DOUBLE-SIDE OPENING DOPPIA APERTURA	FIXING BELTS CINGHIE DI FISSAGGIO	5 YEARS WARRANTY GARANZIA 5 ANNI
TYPE N.18	430	180X78X40	172X73	75	90	14	✓	48 / 95	✓	✓	✓	✓

	MATTE GREY GRIGIO GOFFRATO	METALLIC GREY GRIGIO METALLIZZATO	GLOSSY BLACK NERO LUCIDO	MATTE BLACK NERO GOFFRATO	GLOSSY WHITE BIANCO LUCIDO
TYPE N.18					



TORPEDO



**FARAD TORPEDO,
THANKS TO ITS SIMPLE WIDE DESIGN,
IT'S A PRACTICAL SOLUTION
FOR THE WHOLE FAMILY.**

LO STILE TORPEDO DEI BAULI FARAD,
CON IL SUO DESIGN SOBRIO
E SPAZIOSO, È UNA SOLUZIONE PRATICA
PER TUTTA LA FAMIGLIA.



Double-side opening
Doppia apertura



Standard U bolt fitting
Fissaggio standard con cavallotto a U



Compass opening
Apertura con compasso meccanico



Safety locking system
Chiave antifurto



Three point centralized closure
Chiusura centralizzata in tre punti

TORPEDO



	LITRES LITRI	OUTER DIMENSIONS CM DIMENSIONI ESTERNE CM	INNER DIMENSIONS CM DIMENSIONI INTERNE CM	MAXIMUM LOAD FOR CARS KG CARICO MASSIMO PER AUTO KG	MAXIMUM LOAD FOR MOTOR HOMES KG CARICO MASSIMO PER CAMPER KG	WEIGHT KG PESO KG	FIXING SYSTEM: STANDARD U BOLT FITTING SISTEMA DI FISSAGGIO: FISSAGGIO STANDARD CON CAVALOTTO A U	MIN/MAX DISTANCE BETWEEN BARS CM DISTANZA MIN/MAX TRA LE BARRE CM	CENTRAL LOCKING CHIUSURA CENTRALIZZATA	DOUBLE-SIDE OPENING DOPPIA APERTURA	FIXING BELTS CINGHIE DI FISSAGGIO	5 YEARS WARRANTY GARANZIA 5 ANNI
TYPE N.9	400	160X80X40	154X73	75	90	13	✓	25 / 83	✓	✓	✓	✓

	MATTE GREY GRIGIO GOFFRATO		METALLIC GREY GRIGIO METALLIZZATO		GLOSSY BLACK NERO LUCIDO		MATTE BLACK NERO GOFFRATO		GLOSSY WHITE BIANCO LUCIDO
TYPE N.9									



MAKI+ZIPPY



DISCOVER THE FREEDOM OF TAKING EVERYTHING WITH YOU IN AN ORGANIZED AND SECURE WAY. WITH THE NEW TOWBAR CARGO CARRIER MAKI, MOUNTED ON THE ZIPPY PLATFORM, EVERY TRIP BECOMES A WORRY-FREE PLEASURE!

SCOPRI LA LIBERTÀ DI PORTARE TUTTO CON TE IN MODO ORDINATO E SICURO. CON IL BOX DA GANCIO TRAINO MAKI, MONTATO SULLA PIATTAFORMA ZIPPY, OGNI VIAGGIO DIVENTA UN PIACERE SENZA PENSIERI!



The towbar cargo carrier Maki is mountable on the towbar bike rack Susa. Il box Maki è compatibile con il portabicicli da gancio traino Susa.



MAKI



	LITRES LITRI	OUTER DIMENSIONS CM DIMENSIONI ESTERNE CM	INNER DIMENSIONS CM DIMENSIONI INTERNE CM	MAXIMUM LOAD FOR CARS KG CARICO MASSIMO PER AUTO KG	MAXIMUM LOAD FOR MOTOR HOMES KG CARICO MASSIMO PER CAMPER KG	WEIGHT KG PESO KG	FIXING SYSTEM: STANDARD U BOLT FITTING SISTEMA DI FISSAGGIO: FISSAGGIO STANDARD CON CAVALLOTTO A U	DISTANCE BETWEEN THE FASTENERS DISTANZA TRA I FISSAGGI	CENTRAL LOCKING CHIUSURA CENTRALIZZATA	DOUBLE-SIDE OPENING DOPPIA APERTURA	FIXING BELTS CINGHIE DI FISSAGGIO	5 YEARS WARRANTY GARANZIA 5 ANNI
TYPE N.26	300	132X59X47	126X52X46	50	50	10	✓	44X36	✓	✓	✓	✓
TYPE N.26		MATTE GREY GRIGIO GOFFRATO	METALLIC GREY GRIGIO METALLIZZATO			GLOSSY BLACK NERO LUCIDO			MATTE BLACK NERO GOFFRATO		GLOSSY WHITE BIANCO LUCIDO	

ZIPPY

ZIPPY IS THE PERFECT ACCESSORY TO FIX SAFELY AND EASILY MAKI BOX ON THE TOWBAR.

LO ZIPPY È L'ACCESSORIO PERFETTO PER MONTARE IL BOX MAKI SUL GANCIO TRAINO IN SICUREZZA E FACILITÀ.



ACCESSORIES

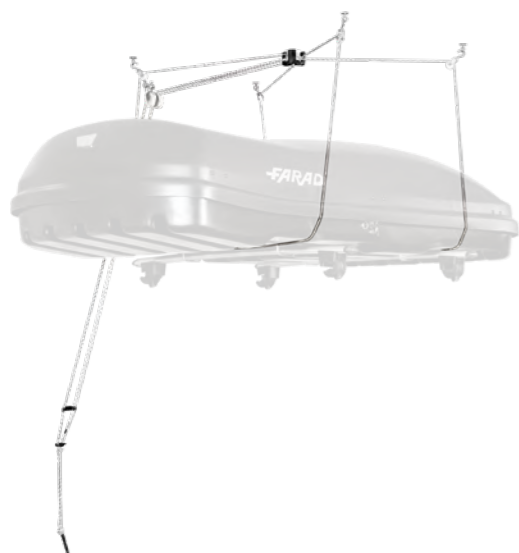

FARAD HOLDER

SUITABLE FOR ALL FARAD ROOF BOXES, IT'S AN IDEAL SOLUTION FOR LIMITED SPACE.

ADATTABILE AD OGNI BAULE FARAD È LA SOLUZIONE IDEALE PER CHI HA PROBLEMI DI SPAZIO.

FARAD SKI

FAST AND EASY TO FIT, THE SKI RACK KEEPS YOUR SKIS SAFER IN THE BOX.

SEMPLICE E PRATICO DA MONTARE, ASSICURA I VOSTRI SCI ALL'INTERNO DEL BOX.

FARAD FAST FIX

THE FITTING SYSTEM FOR A FAST ASSEMBLY AND DISASSEMBLY OF YOUR FARADBOX.

SISTEMA PER MONTARE E SMONTARE RAPIDAMENTE IL VOSTRO FARADBOX.

FARAD QUICK FIX

THE FITTING SYSTEM FOR A FAST ASSEMBLY AND DISASSEMBLY OF YOUR FARADBOX.

SISTEMA PER MONTARE E SMONTARE RAPIDAMENTE IL VOSTRO FARADBOX.



FARAD T-JOINT

THE T-ADAPTER IS SUITABLE FOR ALL FARAD ROOF BARS AND IT ALLOWS A SAFER FITTING OF THE ROOF BOX.

ADATTO A TUTTE LE BARRE FARAD PER UN FISSAGGIO PIÙ SICURO DEL VOSTRO BOX.

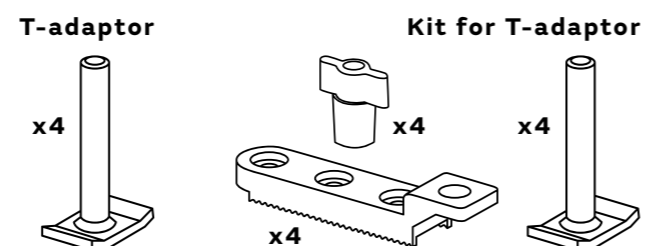

FARAD WIND SPOILER NOISE

SPOILER TO REDUCE WIND NOISE.

SPOILER PER RIDURRE IL RUMORE DEL VENTO.

BIKE RACKS

PORTABICI

LIVE YOUR LOVE OF SPORT
AND SET OFF ON AN ADVENTURE
WITH THE FARAD BIKE RACK THAT SUITS YOU BEST.
THE MUST-HAVE ACCESSORY FOR ALWAYS TAKING
YOUR FAVOURITE TWO-WHEELED TRAVELLING
COMPANION WITH YOU.

ESALTA LA TUA VOGLIA DI SPORT E PARTI ALL'AVVENTURA
CON IL PORTABICI FARAD PIÙ ADATTO ALLE TUE ESIGENZE.
L'ACCESSORIO INDISPENSABILE PER PORTARE SEMPRE CON TE
LA TUA COMPAGNA A DUE RUOTE PREFERITA.







FARAD[®]
made in Italy



MAIRA

The universal bike rack that can be adapted to any type of roof rails fixed manually, theft-proof keys and top-quality materials for rapid assembly and maximum security for your bike.

Il portabicicli da tetto universale adattabile ad ogni tipo di barra portatutto. Fissaggio manuale, chiavi antifurto e materiali di prima scelta assicurano un montaggio rapido e la massima sicurezza per la tua bicicletta.

				
min 25mm / 0.98" max 75mm / 3.0"	max 75x100 / 3.0"x3.9"	min 12" max 29"	min 23mm max 114mm (4.5")	max 1350mm max 25Kg



U-bolt fitting
Attacco con cavallotto



Mountable both right and left
Montabile sia a DX che a SX

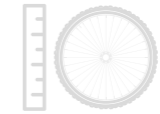

Suitable for all wheel sizes
Adatto a tutte le dimensioni di ruota



Anti-theft key
Chiave antifurto



Pre-assembled / No tools necessary
Premontato / No utensili necessari



"T" fitting
attacco a "T"
Optional / Opzionale



< 4cm need "T" fitting
< 4 cm necessità di attacco a "T"

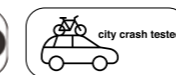

PE SIO

Universal and versatile. Compatible with any type of bar, ensures that you can fit and take down your bike easily and completely safely thanks to the quick fit to the frame. Also for e-bikes.

Universale e versatile. Compatibile ad ogni tipo di barra, garantisce con semplicità il montaggio e lo smontaggio della tua bicicletta in completa sicurezza grazie all'attacco rapido a telaio. Anche per e-bike.

min 25mm / 0.98" max 100mm / 3.9"	max 90x100 / 3.5"x3.9"	min 12" max 29"	min 23mm max 114mm (4.5")	max 1350mm	max 25Kg



"T" fitting
Attacco con fissaggio a "T"

Mountable both right and left
Montabile sia a DX che a SX

Suitable for all wheel sizes
Adatto a tutte le dimensioni di ruota

Anti-theft key
Chiave antifurto

Pre-assembled / No tools necessary
Premontato / No utensili necessari





U-bolt fitting for IRON or IRONQUADRA bars
attacco con cavallotto per barre
IRON o IRONQUADRA
Optional / Opzionale



VARAITA

**Compact and lightweight towbar bike rack,
quick and easy to install on your towbar.
Available for 1 or 2 bikes. Load capacity: 30 kg.
Pre- assembled, tool-free installation and removal.**

Portabici da gancio traino compatto e leggero
che si fissa al gancio traino in pochi secondi.
Disponibile per 1 o 2 bici. Capacità di carico: 30 kg.
Già assemblato non occorrono utensili.

				
ALL	ALL	min 12" max 29"	ALL	ALL
				max 30Kg



WITH LICENSE PLATE HOLDER
CON PORTATARGA

WITH LICENSE PLATE HOLDER + LIGHTS
CON PORTATARGA + FANALI



Distance between the arms 50 cm
Distanza tra le braccia 50 cm



Suitable for all wheel sizes
Adatto a tutte le dimensioni di ruota







Pre-assembled / No tools necessary
Premontato / No utensili necessari

SUSA

Compact and lightweight towbar bike rack, perfect for carrying 2 or 3 bikes with a load capacity of up to 60 kg. Quick and easy installation directly onto your towbar. Pre-assembled and ready for your cycling adventures..

Porta bici da gancio traino compatto e leggero, perfetto per trasportare 2 o 3 bici con una capacità di carico fino a 60 kg. Installazione rapida e semplice direttamente sul tuo gancio traino. Pre-assemblato e pronto all'uso per le tue avventure su due ruote.

				
min 20	max 50	min 12" max 29"	ALL	max 1300mm
				max 60Kg

X 2 BIKES
X 2 BICI



X 3 BIKES
X 3 BICI



The towbar cargo carrier Maki is mountable on the towbar bike rack SUSA
Il box Maki è compatibile con il portabici da gancio traino SUSA



Foldable for storage
Richiudibile per stoccaggio



Access to the trunk compartment
Accesso vano baule



Safe-spacing vertical overturning for parking
Ribaltamento verticale salva spazio per parcheggio



Bike maintenance
Manutenzione bici



BI-COLOR WHEEL COVERS "FREEWHEELING"

COPRICERCHI BICOLORE "A RUOTA LIBERA"

**THE NEW BI-COLOR LINE:
WITH OVER 40 AVAILABLE DESIGNS
AND 30 YEARS EXPERIENCE
IN THE MARKET, FARAD IS FURTHER WIDENING
AND EMBELLISHING ITS VAST PRODUCT RANGE
WITH THE NEW FREEWHEELING LINE.
NEWLY DESIGNED WHEEL TRIMS, WHICH,
THANKS TO A WIDE CHOICE OF COLOURED INSERTS,
ALLOW CUSTOMERS TO EASILY PERSONALIZE
THEIR WHEELS AND THEIR CAR.**

LA NUOVA LINEA BICOLORE
SUL MERCATO DA OLTRE 30 ANNI CON 40 DESIGN DISPONIBILI,
FARAD AMPLIA E IMPREZIOSISCE LA SUA GAMMA,
GIÀ UNA DELLE PIU' VASTE SUL MERCATO.
CON LA NUOVA LINEA A RUOTA LIBERA, DAL DESIGN INNOVATIVO,
GRAZIE AD UNA VASTA SCELTA DI INSERTI COLORATI, FARAD OFFRE AL CLIENTE
LA POSSIBILITÀ DI PERSONALIZZARE L'ASPETTO DELLE PROPRIE RUOTE,
E QUINDI DELLE PROPRIE AUTO, IN POCHI MINUTI E TUTTE LE VOLTE CHE VUOLE.



FARAD[®]
made in Italy

PRE-ASSEMBLED BI-COLOR



ALREADY MOUNTED!
Farad has selected for you the bi-color wheel-trims
Art. 243 packed in 1 box of 4 pieces.

GIÀ MONTATE!
Farad ha selezionato per te le coppe bicolor
Art. 243 imballo in scatola di 4 pezzi.



243 GREY / DARK GREY
14" 15" 16"



243 CHARCOAL GREY / BLACK
14" 15" 16"



243 MATTE BLACK / WHITE
14" 15" 16"

MATERIALS & FEATURES

As all Farad products, wheeltrims are manufactured in Italy according to ISO 9001 quality rules and thoroughly checked during all production stages to guarantee the highest quality standard.

Wheel trims are made in PA66 M20 + PP, a first choice material, to provide a product which is both resistant to brakes temperatures and flexible in case of collision.

A double coat of water paint, finished by a glossy metallic layer which, not only results in an elegant product but guarantees also the paint's resistance in line with OEM specifications.

The wheel trims are fixed by a metallic ring and tested for suitability to most of car wheels, following OEM requirements.

Come tutti i prodotti FARAD, i copricerchi sono prodotti in Italia rispettando tutti i criteri ISO 9001 e vengono controllati al 100% ad ogni passaggio della lavorazione per ottenere standard di qualità estremamente elevati.

Prodotti in materiale di prima scelta, Pa66 M20 + PP, per ottenere un prodotto resistente alla temperatura dei freni ma allo stesso tempo flessibile agli urti.

Doppia mano di vernice all'acqua rivestita da uno strato di metallizzato lucido che, oltre ad offrire un prodotto lucente ed elegante, fornisce una tenuta della vernice sul copricerchio secondo specifiche OEM.

Fissati alla ruota tramite anello metallico, vengono testati per essere compatibili con la maggior parte delle ruote auto con prove di tenuta secondo specifiche OEM.



240B 14" 15" 16"
GLOSSY BLACK



240B MATTE 14" 15" 16"
MATTE BLACK



240G 14" 15" 16"
GREY



241B 14" 15" 16"
GLOSSY BLACK



241B MATTE 14" 15" 16"
MATTE BLACK



241G 14" 15" 16"
GREY



243B 13" 14" 15" 16"
GLOSSY BLACK



243B MATTE 13" 14" 15" 16"
MATTE BLACK



243G 13" 14" 15" 16"
GREY

240B 14" 15" 16" **GLOSSY/MATTE BLACK**

240G 14" 15" 16" **GREY**



240INS 14" 15" 16"
BLACK



240INS 14" 15" 16"
DARK GREY



240INS 14" 15" 16"
GREEN



240INS 14" 15" 16"
BLACK



240INS 14" 15" 16"
DARK GREY



240INS 14" 15" 16"
GREEN



240INS 14" 15" 16"
DARK BLUE



240INS 14" 15" 16"
BLUE



240INS 14" 15" 16"
LIGHT BLUE



240INS 14" 15" 16"
DARK BLUE



240INS 14" 15" 16"
BLUE



240INS 14" 15" 16"
LIGHT BLUE



240INS 14" 15" 16"
WHITE



240INS 14" 15" 16"
LIGHT GREY



240INS 14" 15" 16"
VIOLET



240INS 14" 15" 16"
WHITE



240INS 14" 15" 16"
LIGHT GREY



240INS 14" 15" 16"
VIOLET



240INS 14" 15" 16"
RED



240INS 14" 15" 16"
ORANGE



240INS 14" 15" 16"
YELLOW



240INS 14" 15" 16"
RED



240INS 14" 15" 16"
ORANGE



240INS 14" 15" 16"
YELLOW

241B 14" 15" 16" **GLOSSY/MATTE BLACK**

241G 14" 15" 16" **GREY**



241INS 14" 15" 16"
BLACK



241INS 14" 15" 16"
DARK GREY



241INS 14" 15" 16"
GREEN



241INS 14" 15" 16"
BLACK



241INS 14" 15" 16"
DARK GREY



241INS 14" 15" 16"
GREEN



241INS 14" 15" 16"
DARK BLUE



241INS 14" 15" 16"
BLUE



241INS 14" 15" 16"
LIGHT BLUE



241INS 14" 15" 16"
DARK BLUE



241INS 14" 15" 16"
BLUE



241INS 14" 15" 16"
LIGHT BLUE



241INS 14" 15" 16"
WHITE



241INS 14" 15" 16"
LIGHT GREY



241INS 14" 15" 16"
VIOLET



241INS 14" 15" 16"
WHITE



241INS 14" 15" 16"
LIGHT GREY



241INS 14" 15" 16"
VIOLET



241INS 14" 15" 16"
RED



241INS 14" 15" 16"
ORANGE



241INS 14" 15" 16"
YELLOW



241INS 14" 15" 16"
RED



241INS 14" 15" 16"
ORANGE



241INS 14" 15" 16"
YELLOW

243B 14" 15" 16" **GLOSSY/MATTE BLACK**

243G 14" 15" 16" **GREY**



243INS 14" 15" 16"
BLACK



243INS 14" 15" 16"
DARK GREY



243INS 14" 15" 16"
GREEN



243INS 14" 15" 16"
BLACK



243INS 14" 15" 16"
DARK GREY



243INS 14" 15" 16"
GREEN



243INS 14" 15" 16"
DARK BLUE



243INS 14" 15" 16"
BLUE



243INS 14" 15" 16"
LIGHT BLUE



243INS 14" 15" 16"
DARK BLUE



243INS 14" 15" 16"
BLUE



243INS 14" 15" 16"
LIGHT BLUE



243INS 14" 15" 16"
WHITE



243INS 14" 15" 16"
LIGHT GREY



243INS 14" 15" 16"
VIOLET



243INS 14" 15" 16"
WHITE



243INS 14" 15" 16"
LIGHT GREY



243INS 14" 15" 16"
VIOLET



243INS 14" 15" 16"
RED



243INS 14" 15" 16"
ORANGE



243INS 14" 15" 16"
YELLOW



243INS 14" 15" 16"
RED



243INS 14" 15" 16"
ORANGE



243INS 14" 15" 16"
YELLOW

INSERTS COLOURS

12 fantastic colours to be combined with your wheel cover.

12 fantastici colori da abbinare ai vostri copricerchi

240 INS 14" 15" 16"



241 INS 14" 15" 16"



243 INS 14" 15" 16"



ASSEMBLY INSTRUCTIONS



UNIVERSAL WHEEL TRIMS

COPRICERCHI UNIVERSALI

WHEEL COVERS

FARAD HAS BEEN IN THE MARKET FOR MORE THAN 30 YEARS, WITH THE WIDEST RANGE OF WHEEL TRIMS IN EUROPE, ESTABLISHING AS ONE OF THE LEADERS. THE PRODUCTS ARE AVAILABLE IN 40 DIFFERENT PATTERNS, FROM 12 TO 17 INCHES. WHEEL TRIMS ARE MANUFACTURED IN ITALY ACCORDING TO ISO 9001 QUALITY RULES, AND CHECKED AFTER EVERY STEP OF PRODUCTION, IN ORDER TO OFFER A HIGH QUALITY STANDARD.

MATERIALS

WHEEL TRIMS ARE MADE WITH FIRST CHOICE MATERIALS, HENCE FARAD CAN OFFER A PRODUCT BOTH RESISTANT TO BRAKES TEMPERATURE AND FLEXIBLE IN CASE OF COLLISION.

PAINTING

DOUBLE LAYER OF WATER PAINT, COVERED BY A SHINY METALLIC LAYER, WHICH GUARANTEES A BRILLIANT PRODUCT AND A STRONG ADHESION OF THE PAINTING AS WELL, ACCORDING TO OEM REQUIREMENTS.

FIXING ON THE RIM

WHEEL TRIMS ARE FIXED BY A METALLIC RING; THEY ARE TESTED IN ORDER TO BE SUITABLE TO MANY CAR WHEELS, HOLDING TESTS ACCORDING TO OEM REQUIREMENTS.

PARTNERSHIP

FARAD COOPERATES WITH MANY CAR MANUFACTURERS TO REALIZE SPARE WHEEL TRIMS WITH MATERIALS AND COATINGS CHOSEN BY THE CUSTOMER ITSELF.

COPRICERCHI

FARAD È PRESENTE SUL MERCATO DA PIÙ DI 30 ANNI, CON UNA DELLE PIÙ AMPIE GAMME DI COPRICERCHI IN EUROPA, PONENDOSI COME UNO DEI LEADER. I PRODOTTI SONO DISPONIBILI IN 40 DIVERSI MODELLI, DA 12 A 17 POLLICI. PRODOTTI IN ITALIA SEGUENDO LE SPECIFICHE DI QUALITÀ ISO 9001 E CONTROLLATI AL 100% DOPO OGNI PASSAGGIO DI LAVORAZIONE PER OTTENERE UN ELEVATO STANDARD DI QUALITÀ.

MATERIALI

PRODOTTI IN MATERIALE DI PRIMA SCELTA, PER OTTENERE UN PRODOTTO RESISTENTE ALLA TEMPERATURA DEI FRENI MA ALLO STESSO TEMPO FLESSIBILE AGLI URTI.

VERNICE

DOPPIA MANO DI VERNICE ALL'ACQUA RIVESTITA DA UNO STRATO DI METALLIZZATO LUCIDO CHE, OLTRE AD OFFRIRE UN PRODOTTO LUCENTE ED ELEGANTE, FORNISCE UNA TENUTA DELLA VERNICE SUL COPRICERCHIO SECONDO SPECIFICHE OEM.

TENUTA SULLA RUOTA

AGGRAPPATI SULLA RUOTA TRAMITE ANELLO METALLICO, VENGONO TESTATI PER ESSERE COMPATIBILI CON LA MAGGIOR PARTE DELLE RUOTE AUTO CON PROVE DI TENUTA SECONDO SPECIFICHE OEM.

PARTNERSHIP

FARAD COLLABORA CON NUMEROSE CASE AUTOMOBILISTICHE PER LA REALIZZAZIONE DI COPRICERCHI SPECIFICI CON MATERIALI E VERNICI SECONDO LE NECESSITA' DEL CLIENTE.



FARAD[®]
made in Italy

UNIVERSAL WHEEL TRIMS



13" 14"
PART NR. **201** SILVER



13" 14"
PART NR. **202** SILVER



12" 13" 14" 15" 16"
PART NR. **204** SILVER



13"
PART NR. **213** SILVER



12" 13" 14" 15"
PART NR. **214** SILVER



13" 14" 15"
PART NR. **216** SILVER



13" 14"
PART NR. **205** SILVER



13" 14" 15"
PART NR. **206** SILVER



13"
PART NR. **207** SILVER



13" 14" 15"
PART NR. **216** CHROMED CAP



13" 14"
PART NR. **217** SILVER



13" 14" 15"
PART NR. **218** SILVER



13" 14"
PART NR. **208** SILVER



13" 14" 15"
PART NR. **209** SILVER



13" 14" 15"
PART NR. **210** SILVER



13" 14" 15"
PART NR. **219** SILVER



13" 14" 15"
PART NR. **219C** SILVER



14"
PART NR. **219C** CHROMED



13" 14"
PART NR. **211** SILVER



13" 14" 15" 16"
PART NR. **212** SILVER



13" 14" 15" 16"
PART NR. **212** CHROMED NUTS



13" 14" 15"
PART NR. **220** SILVER



13"
PART NR. **221** SILVER



15"
PART NR. **222** SILVER

UNIVERSAL WHEEL TRIMS



13" 14" 15" 16"
PART NR. **224** SILVER



15"
PART NR. **225** SILVER



15"
PART NR. **225** CHROMED



14" 15" 16"
PART NR. **235** SILVER



15"
PART NR. **235** BLACK



14" 15" 16"
PART NR. **236** SILVER



13" 14" 15"
PART NR. **226** SILVER



13" 14" 15"
PART NR. **227** SILVER



13" 14" 15" 16"
PART NR. **228** SILVER



14" 15" 16"
PART NR. **237** SILVER



14" 15" 16"
PART NR. **238** SILVER



15"
PART NR. **239** SILVER



13" 14" 15"
PART NR. **229** SILVER



13" 14" 15" 16"
PART NR. **230** SILVER



16"
PART NR. **231** SILVER



13" 15"
PART NR. **404** SILVER



14" 15" 16"
PART NR. **242** SILVER



14" 15" 16"
PART NR. **242** GLOSSY BLACK



13" 14" 15" 16"
PART NR. **232** SILVER



13" 14" 15" 16" 17"
PART NR. **233** SILVER



13" 14" 15" 16"
PART NR. **234** SILVER



14" 15" 16"
PART NR. **242** MATTE BLACK



14" 15" 16"
PART NR. **242** CHARCOAL GREY

UNIVERSAL WHEEL COVERS APPLICATIONS ON VANS

Applicazioni RENAULT - RENAULT applications

VECCHIO MASTER 16" 2010-2019	TRAFIC 16" 2014>
204 16"	204 16"
224 16"	228 16"
228 16"	230 16"
230 16"	233 16"
231 16"	236 16"
233 16"	238 16"
234 16"	
236 16"	
NUOVO MASTER 16" 2019>	
204 16"	
230 16"	
233 16"	
236 16"	

Applicazioni MERCEDES - MERCEDES applications

SPRINTER 16" 2° SE-RIE 2006-2018	SPRINTER 16" 3° SE-RIE 2018>	VITO - VIANO 16"
204 16"	204 16"	204 16"
228 16"	228 16"	228 16"
230 16"	230 16"	230 16"
233 16"	233 16"	233 16"
236 16"	236 16"	236 16"
238 16"	238 16"	238 16"

Applicazioni CITROËN - CITROËN applications

JUMPY 16" 2016>	JUMPER 15" 2006-2014	JUMPER 15" 2014>
204 16"	209 15" - 3mm	209 15" - 3mm
212 16"	210 15" - 3mm	210 15" - 3mm
224 16"	236 15" - 2 mm	236 15" - 2mm
228 16"	238 15" - 2mm	238 15" - 2mm
230 16"		JUMPER 16" 2014>
231 16"		228 16" - 3 mm
232 16"		236 16" - 3 mm
233 16"		238 16" - 3 mm
234 16"		
235 16"		
236 16"		
237 16"		
238 16" - 3 mm		

Applicazioni PEUGEOT - PEUGEOT applications

EXPERT 16" 2016>	BOXER 15" 2006-2014	BOXER 15" 2014>
204 16"	209 15" -3mm	209 15" - 3mm
212 16"	210 15" -3mm	210 15" - 3mm
224 16"	236 15" -2mm	236 15" - 2mm
228 16"	238 15" -2 mm	238 15" - 2mm
230 16"		BOXER 16' 2014>
231 16"		228 16" - 3 mm
232 16"		236 16" - 3 mm
233 16"		238 16" - 3 mm
234 16"		
235 16"		
236 16"		
237 16"		
238 16" -3mm		

Applicazioni OPEL - OPEL applications

VIVARO 16" 2019>	VECCHIO MOVANO 16" 2006-2021	NUOVO MOVANO 16" 2022>
204 16"	204 16"	228 16" - 3 mm
228 16"	224 16"	236 16" - 3 mm
230 16"	228 16"	238 16" - 3 mm
233 16"	230 16"	
236 16"	231 16"	
238 16"	233 16"	
	234 16"	
	236 16"	

Applicazioni VOLKSWAGEN - VOLKSWAGEN applications

TRANSPORTER 16" 2014>	CRAFTER 16" 2° SERIE
204 16"	204 16"
228 16"	230 16"
230 16"	233 16"
233 16"	236 16"
236 16"	237 16"

Applicazioni FORD - FORD applications

TRANSIT 16" 2014> no ruote gemellate/ no twin wheels	TRANSIT 16" 2014> solo ruote gemellate posteriori/only rear twin wheels
204 16" -3mm	204 16" -3mm
224 16" -3mm	212 16" -3mm
230 16" -3mm	224 16" -3 mm
232 16" -3mm	228 16" -3mm
233 16" -3mm	230 16" -3mm
234 16" -3mm	231 16" -3mm
235 16" - 3mm	232 16" -3mm
236 16" - 3mm	233 16" -3mm
237 16" - 3mm	234 16" - 3mm
238 16" - 3 mm	235 16" -3mm
	236 16" -3mm
	237 16" -3mm
	238 16" -3mm

Applicazioni IVECO IVECO applications

DAILY 16" solo ruote gemellate
204 16" -3mm
212 16" -3mm
224 16" -3mm
228 16" -3mm
230 16" -3mm
231 16" -3mm
232 16" -3mm
233 16" -3mm
234 16" -3mm
235 16" -3mm
236 16" -3mm
237 16" -3mm
238 16" -3mm

Applicazioni NISSAN NISSAN applications

PRIMESTAR - 16"
238 16" - 3mm

Applicazioni FIAT - FIAT applications

DUCATO 2006-2014 15"	DUCATO 15" 2014>	SCUDO 16" 2022>	TALENTO 16"
209 15" -3mm	209 15" - 3mm	204 16"	204 16"
210 15" -3mm	210 15" - 3mm	212 16"	228 16"
236 15" -2mm	236 15" - 2mm	224 16"	230 16"
238 15" -2 mm	238 15" - 2mm	228 16"	233 16"
	DUCATO 16" 2014>	230 16"	236 16"
	228 16" - 3 mm	231 16"	238 16"
	236 16" - 3 mm	232 16"	
	238 16" - 3 mm	233 16"	
		234 16"	
		235 16"	
		236 16"	
		237 16"	
		238 16" -3mm	

WIND DEFLECTORS

DEFLETTORI D'ARIA

FARAD WIND DEFLECTORS "MINI DEFLECTOR".

MANUFACTURED FROM SHOCKPROOF AND SPLINTERPROOF MATERIAL, "MINI DEFLECTOR" IS AN IMPORTANT ACCESSORY FOR ALL CARS. FARAD SUPPLIES MOST CAR MANUFACTURERS WITH THIS ITEM. NOT ONLY DO DEFLECTORS IMPROVE THE APPEARANCE OF THE VEHICLE, BUT THEY ALSO PROVIDE THE FOLLOWING BENEFITS AND FEATURES:

- POSSIBILITY TO KEEP THE WINDOWS OPEN IN ANY WEATHER CONDITIONS
- OPTIMIZE AIR CIRCULATION IN CASE OF RAIN OR PRESENCE OF SMOKERS INSIDE THE CAR
- REDUCTION OF THE USE OF AIR CONDITIONING, RESULTING IN A REDUCTION OF FUEL CONSUMPTION
- REDUCTION OF NOISE CAUSED BY THE AIR FLOW
- SAFER AND RELAXED DRIVING WITHOUT DISTRACTIONS
- THE COLOR IS TRANSPARENT SMOKE GREY

DEFLETTORI D'ARIA FARAD "MINI DEFLECTOR".

COSTRUITI CON MATERIALE DI ULTIMA GENERAZIONE ANTIURTO ED ANTISCHEGGE, I DEFLETTORI D'ARIA FARAD COSTITUISCONO UN ACCESSORIO PER TUTTE LE AUTO. IMPORTANTI CASE AUTOMOBILISTICHE UTILIZZANO FARAD COME FORNITORE UFFICIALE DI QUESTO ARTICOLO. TRA LE MOLTEPLICI UTILITÀ, OLTRE AD UN ABBELLIMENTO ESTETICO DELLA VETTURA, LE SEGUENTI CARATTERISTICHE:

- POSSIBILITÀ DI MANTENERE IL FINESTRINO APERTO CON QUALSIASI CONDIZIONE CLIMATICA
- RICIRCOLO DELL'ARIA IN CASO DI PIOGGIA O PRESENZA DI FUMATORI IN AUTO
- CONSISTENTE DIMINUZIONE DELL'USO DEL CLIMATIZZATORE
- RISPARMIO ENERGETICO CON CONSEGUENTE RECUPERO SUI CONSUMI
- RIDUZIONE DEL RUMORE CAUSATO DAL PASSAGGIO DELL'ARIA ALL'INTERNO DELL'ABITACOLO
- STILE DI GUIDA PIÙ CONFORTEVOLE E SICURO LONTANO DA PERICOLOSE DISTRAZIONI
- COLORE FUMÈ SCURO

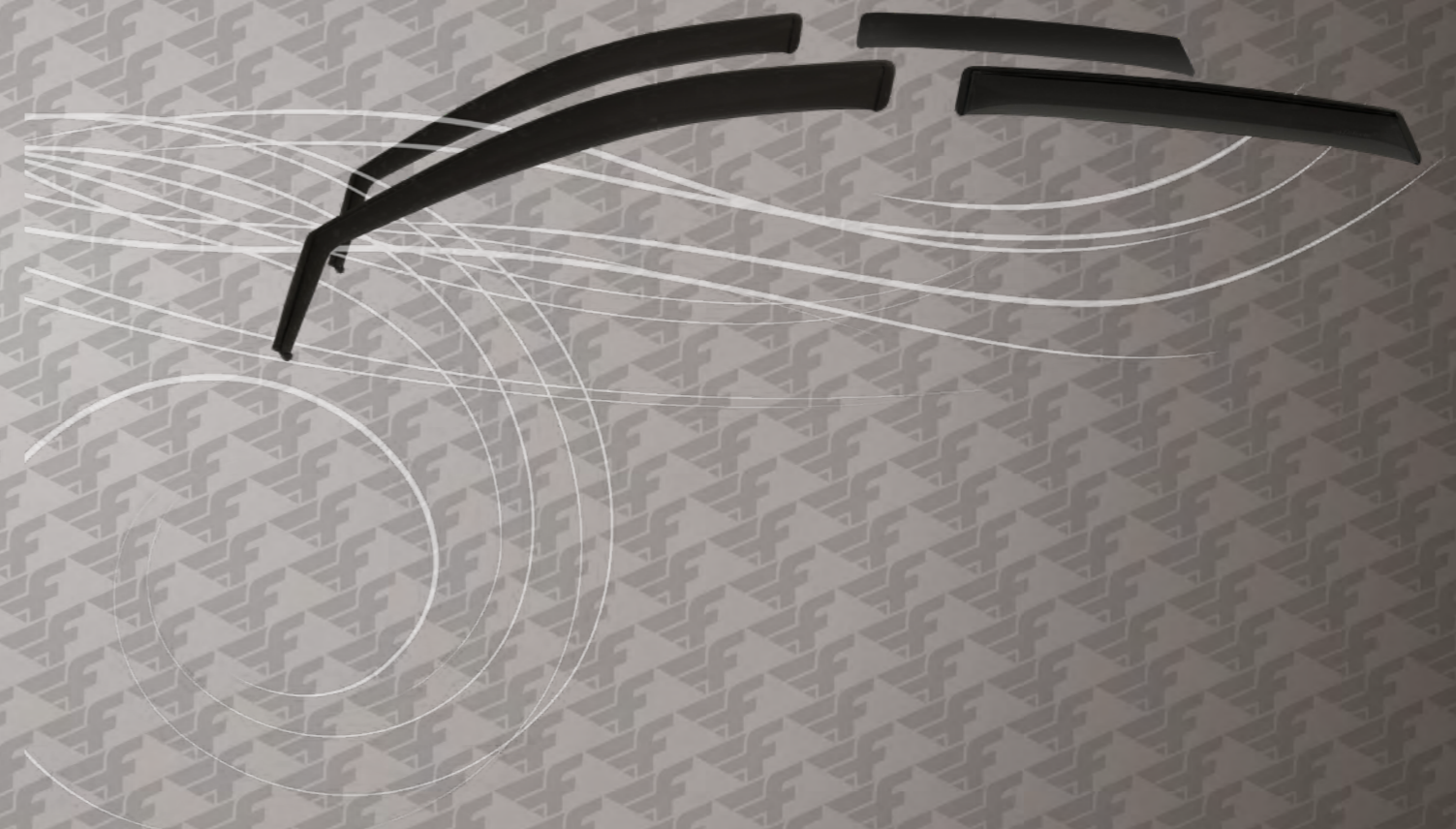

FARAD®
made in Italy

MINI DEFLECTOR

FARAD "Mini Deflector" is easy to install.
An adhesive fixing version "With Sticker" is also available.
Farad offers a large range of wind deflectors for vans and trucks.
Thanks to its aerodynamic and attractive shape,
it becomes an integral part of the car.

I deflettori d'aria FARAD "Mini Deflector" sono facili da installare.
Disponibile inoltre, per alcuni modelli d'auto, una versione con fissaggio
adesivo "With Sticker". Non trascurabile la vasta gamma di applicazioni per i camion.
Grazie alla loro forma aerodinamica e piacevole alla vista, appaiono come parte
integrante dell'auto e dei veicoli commerciali.



MINI DEFLECTOR KITS

FRONT - REAR MINI DEFLECTOR KITS

In addition to the wide range of front door deflectors
we can supply a series of complete kits for front
and rear doors.

KIT MINI DEFLECTOR ANTERIORE-POSTERIORE

Oltre ad una vastissima gamma di deflettori per le portiere anteriori
forniamo tutta una serie di kit completi per i finestrini anteriori e posteriori.

TRUCK MINI DEFLECTOR



Our team, using the latest
computerised systems, develops specific
designs also for the most models of trucks.
Our range is constantly updated to guarantee
high quality products, famous the world over.

Il nostro team, grazie a sistemi computerizzati,
sviluppa un design specifico anche per la maggior parte dei modelli di camion.
un costante aggiornamento della gamma garantisce alla clientela
un prodotto di alta qualità famosa in tutto il mondo.

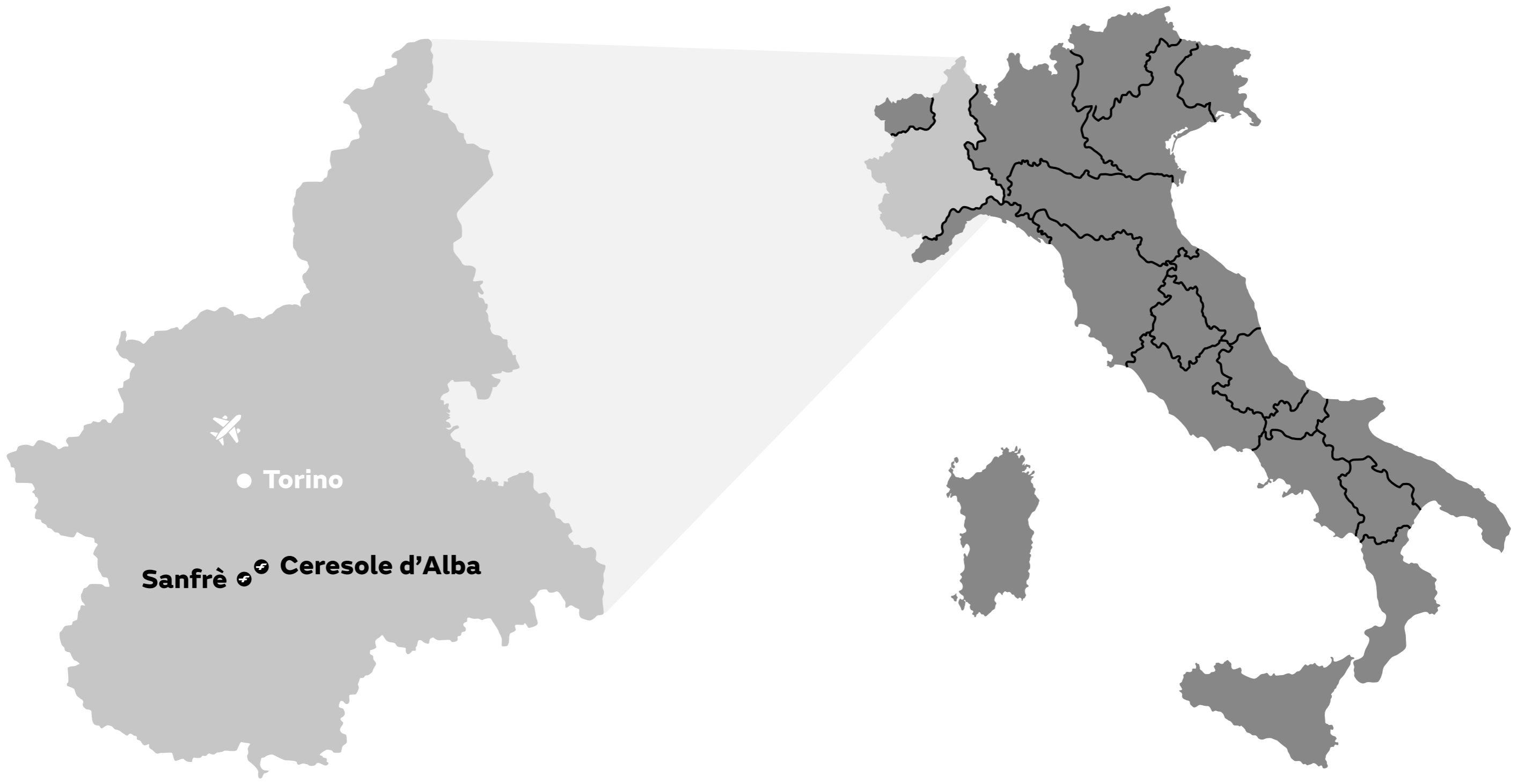

● Torino

Sanfrè ● **Ceresole d'Alba**

FARADWORLD.COM

EDIZIONE 07/2024